

MODEL 5 PROVER & SOFTWARE MANUAL

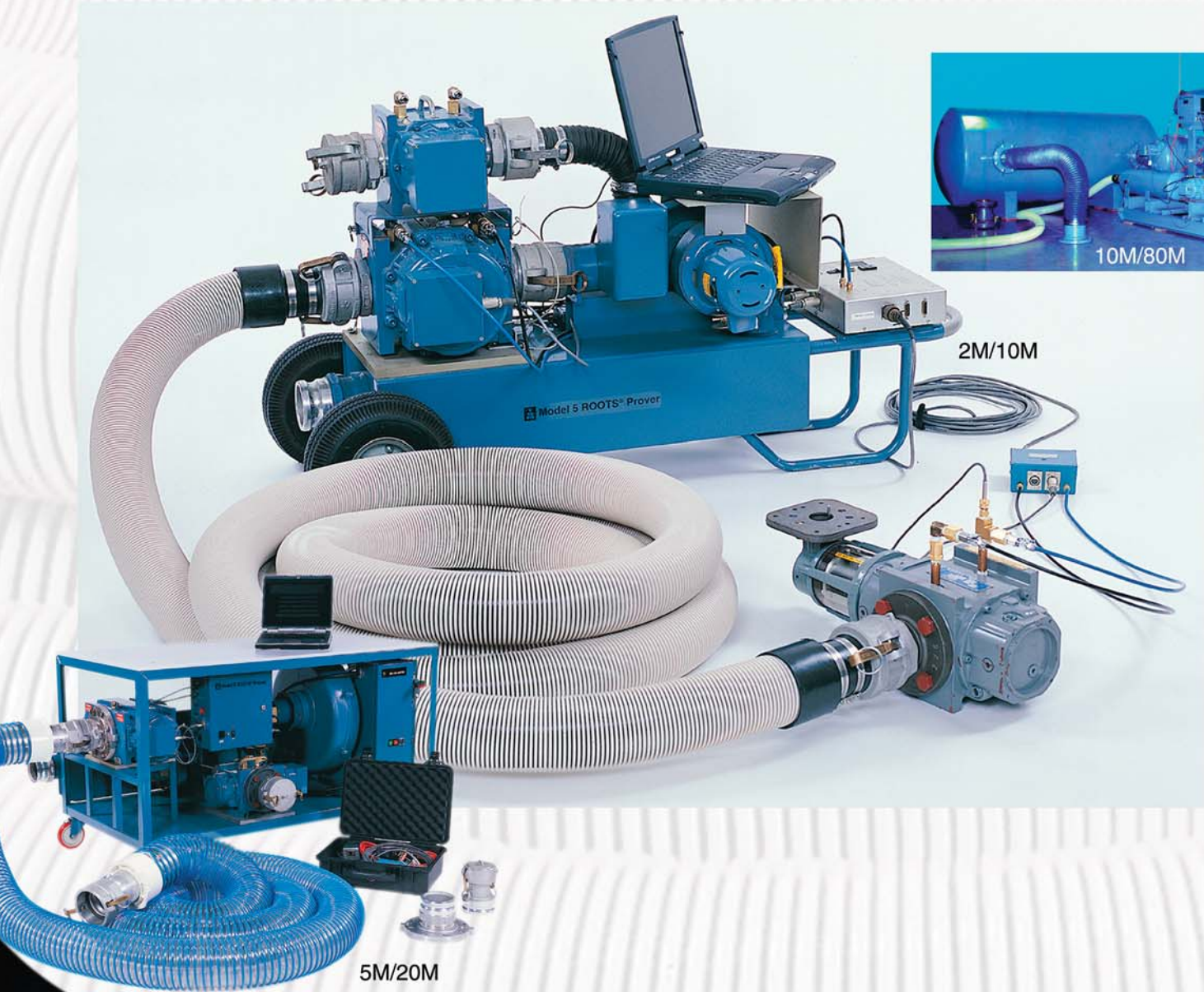


Table of Contents

1. Introduction	1
1.1 Receiving and Inspection at time of delivery	1
1.2 General Information	1
1.3 Component List	2
1.4 Optional Accessories	5
1.5 Theory of Operation	5
1.6 Precautions	5
1.7 Specifications (excluding Computer)	7
2. Installing the Model 5 Prover Software	8
2.1 Minimum System Requirements	8
2.2 Compatibility Issues	8
2.3 Software Installation	8
2.4 Verifying the Proper Files Are Loaded	9
2.5 Upgrade Notice	9
3. The Startup Screen and Help	10
3.1 The Startup Screen	10
3.2 The Help Directory	10
4. Setting Prover Options	11
4.1 The Set Prover Options Screen	11
4.2 Changing Units of Measure	12
4.3 Editing Passwords	12
5. Configuring a Meter Test	13
5.1 Prover Capacity	13
5.2 Test Control Mode	13
5.3 Meter Output	14
5.4 Drive Rate or Pulses Per Test (PPT)	15
5.5 Test Volume	16
5.6 Base Pressure Correction	16
5.7 Flow Rate	16
5.8 Test Duration	17
5.9 Selecting the Number of Test Repeats	17
5.10 Save, Close and Change	17

6. Equipment Setup	18
6.1 Field Meter Setups	18
7. Running a Meter Test	24
7.1 Selecting a Preconfigured Test	24
7.2 The Pretest Error Message Screen	24
7.3 The Meter Test Screen	26
7.4 System Readouts	27
7.5 Calculated Values	28
8. Test Results and Reports	29
8.1 Reviewing, Saving, and Printing Test Results	29
8.2 The Report Manager	29
9. Calibrating the Prover	31
9.1 Reaching the Prover Calibration Screen	31
9.2 The Conversion Tool	33
9.3 How to Calibrate the A/D Converter Check Point	33
9.4 How to Calibrate the Atmospheric Pressure Transducer	33
9.5 How to Calibrate the Master Meter Inlet Pressure Transducer	34
9.6 How to Calibrate the Field Meter Inlet Pressure Transducer	34
9.7 How to Calibrate the Master Meter Temperature Probe	35
9.8 How to Calibrate the Field Meter Temperature Probe	35
9.9 How to Calibrate the Master Meter Outlet Pressure Transducer	36
9.10 How to Calibrate the Field Meter Outlet Pressure Transducer	36
10. Prover Maintenance	37
10.1 Master Meter Hours of Operation	37
10.2 Prover Self Test	37
10.3 Master Meter Differential Pressure Test	38
10.4 System Leak Test	38
10.5 Meter Purge	40
10.6 Maintenance Recommendations	40
10.7 Maintenance Check List	41
11. Problem Identification and Resolution	43
11.1 Common Operation Problems	43
11.2 Troubleshooting Error Messages	44
11.3 Assistance & Service Procedure	46
11.4 Return Authorization Procedure	46
Appendix	47
Spare Parts List	52
2 Year Warranty	53

1. Introduction

1.1 Receiving and Inspection at time of delivery:

1. Check the packing list to account for all items received.
2. Inspect the shipping container for damage. Record any visible damage or shortages on the delivery record.
3. File a claim with the carrier.
4. Notify your ROOTS® Prover supplier immediately.

NOTE:

Do not accept any shipment with evidence of mishandling without making an immediate inspection for damage prior to signing the carrier's delivery record. Do not attempt repairs or adjustments, as doing so may be a basis for voiding all claims for warranty or insurance claim with carrier.

1.2 General Information

The Model 5 ROOTS Prover is an integrated computer controlled system designed for shop or field proving of rotary and diaphragm-type positive displacement gas meters (80M for shop use only). The Prover is designed for transfer proving utilizing air only as the test medium, and electric blowers mounted on a manifold or a skid provide the test air flow (vacuum).

The Prover system consists of the following major components: Master Meter(s) as the measurement reference standard; pressure and temperature Transducers; Blower(s); flexible hose(s); electronic cables and accessories with a storage case; a Flow Rate Controller for automatic flow rate adjustment and test sequencing; and computer software for calculations and presentation of the flow test data. The Prover also has the unique capability to test ROOTS meters equipped with the Integral Micro Corrector (IMC/W2). A personal computer (not included) is required to run the software.

The software program stores predetermined Field Meter test configurations. It performs all calculations at the end of each test run and displays the pressure and temperature differentials, Field Meter proof, Field Meter accuracy, and percent error. Test reports may be saved to diskette, the PC hard drive, and/or may be printed. You can configure the software for Imperial or Metric display and storage of data.

The Model 5 10M, 2M/10M ROOTS Prover and Mobile 5M ROOTS Prover are portable units. They may be transported into the field for on-site testing. The Prover is a precision instrument - operate and maintain it in accordance with factory recommendations as outlined in this manual to ensure accurate and repeatable results. Transport it with care and ensure that it is properly secured and covered for protection from moisture and dirt.

The blowers are not explosion proof. Do not operate them when testing in a hazardous area. Do not operate the Prover in the presence of explosive or flammable gasses or an explosion may result. The Prover system is not designed for intrinsic safety.



1.3 Component List

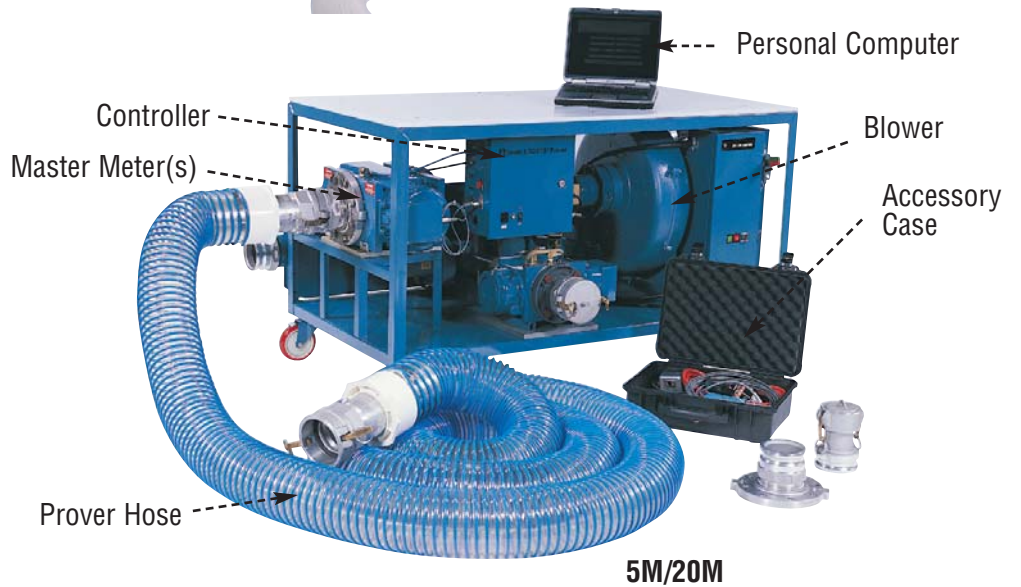
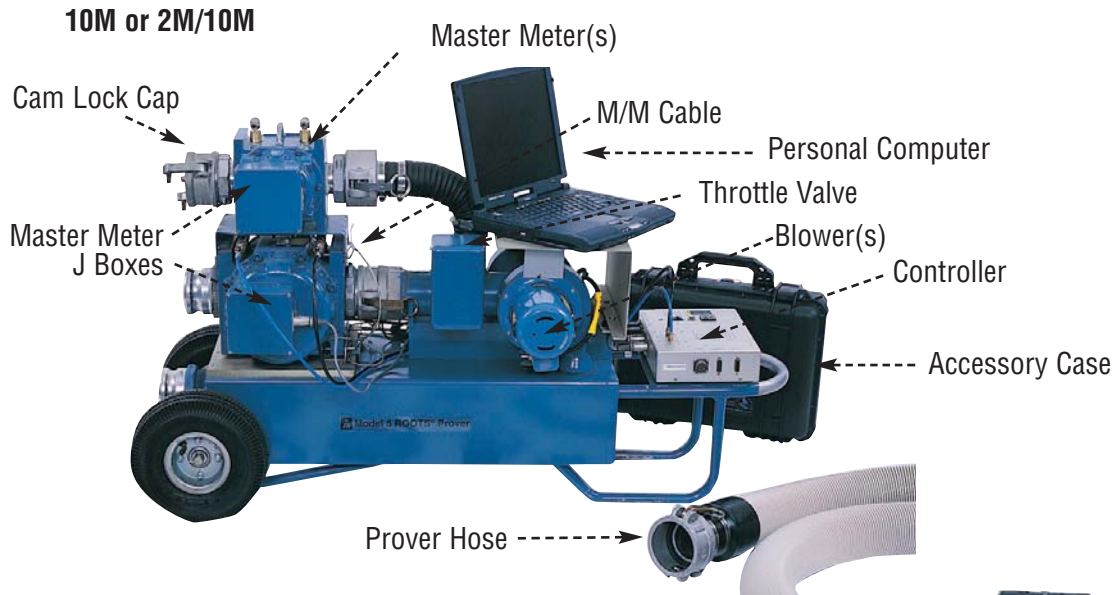
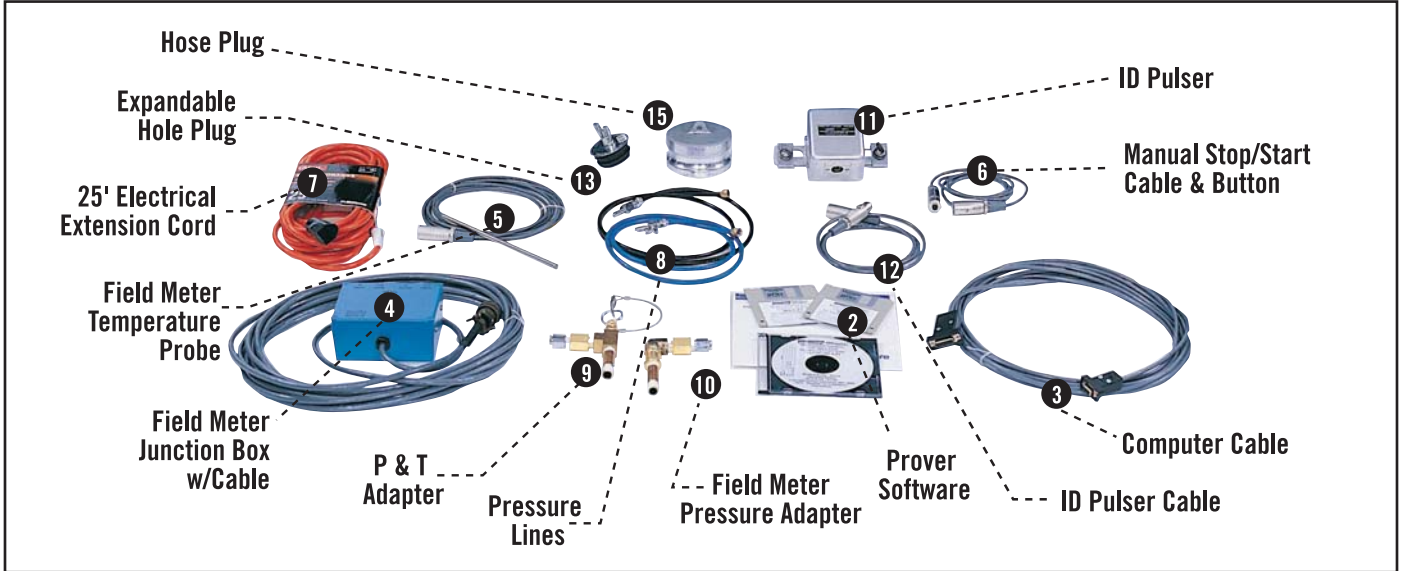
The following is a complete list and physical description of the items available for the Model 5 ROOTS® Prover. Your particular order may or may not include all of the components listed below. If any items that you ordered are missing or damaged, call the Customer Service Department at Dresser Roots Meters & Instruments at 1-800-521-1114 or 832-590-2303.

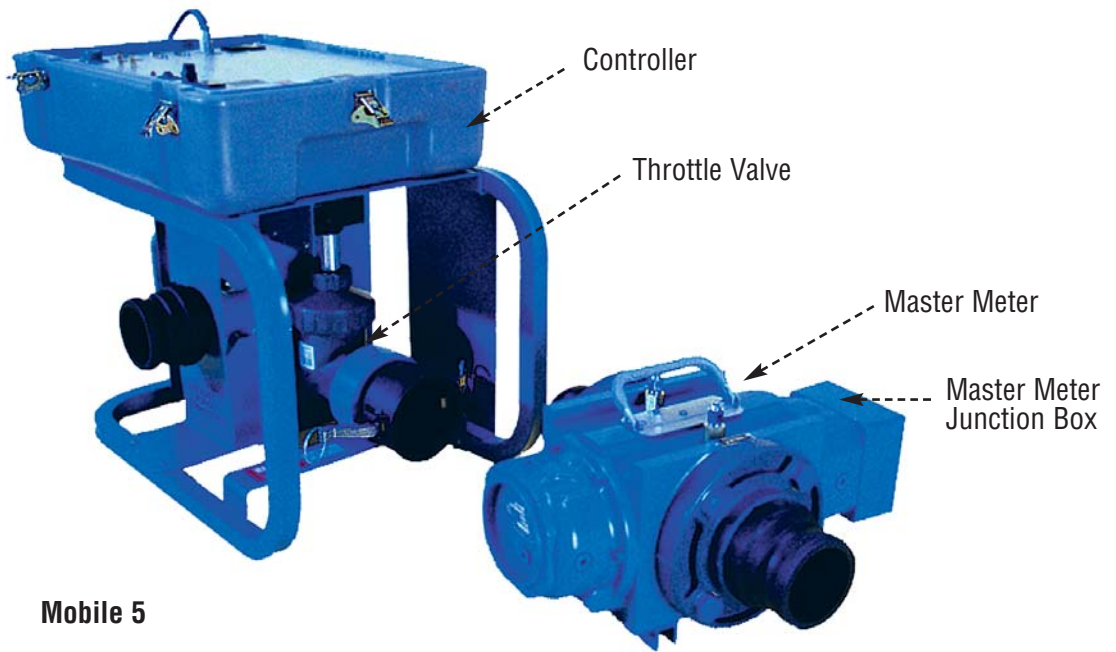
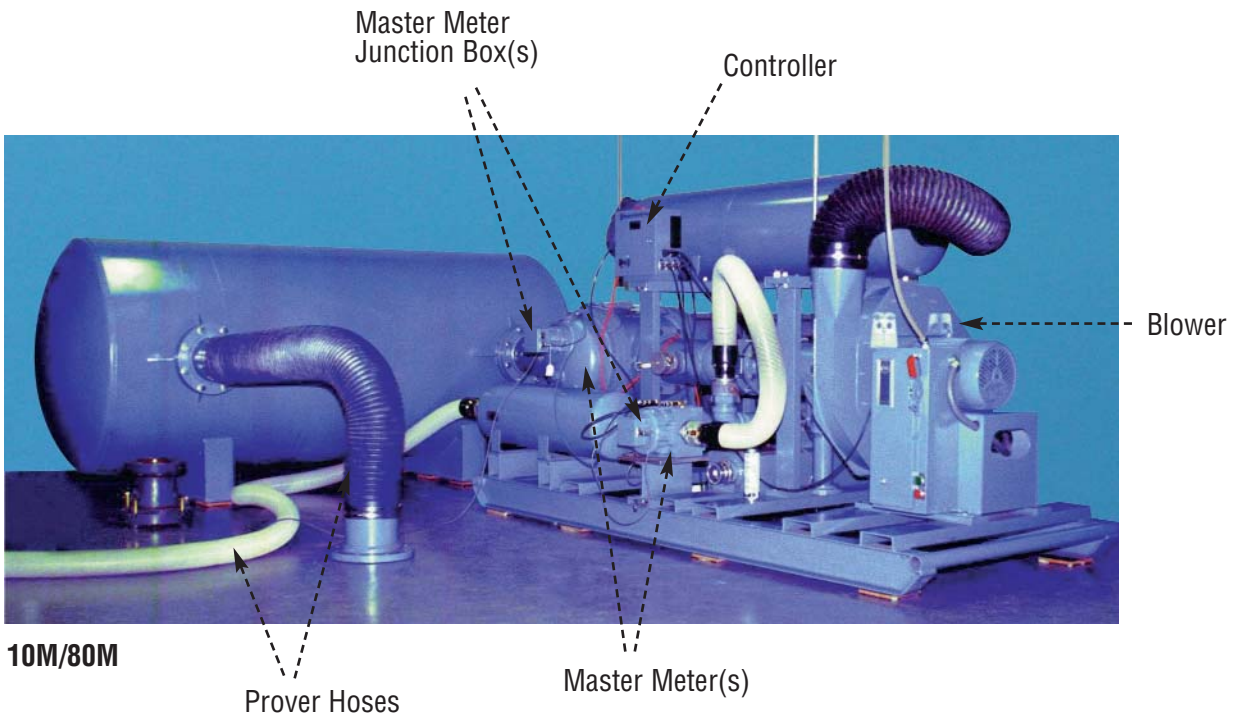


Figure 1: Model 5 ROOTS Prover

1. **Black Accessory Case** – A briefcase-sized, black container used for storing Model 5 Prover accessory equipment.
2. **Prover Software** – 1 Windows CD located in the lid of the black accessory case behind the foam padding. It contains the necessary software for operating the Prover.
3. **Computer Cable** – An RS-232 capable data transmission quality cable with a 15-pin connector at one end and a 9-pin connector at the other end.
4. **Field Meter Junction Box** – A rectangular box, approximately 5 x 5 inches. Attached is a 30 ft. cable with a round 12-pin connector at one end.
5. **Field Meter Temperature Probe** – A 6 in. long, 1/4 in. diameter silver tube with a cable extending from it. The end of the cable has a 4-pin connector.
6. **Manual Start/Stop Cable and Button** – A cable with a 5-pin connector at one end and a push button at the opposite end.
7. **25' Power Cord**
8. **Pressure Lines** – 1/4 in. diameter nylon tubing with compression nuts attached to each end. There are four pressure lines - blue for Input, black for Output. One pair of blue and black lines is for the Master Meter(s) and the other is for the field or test meter.
9. **P&T (Pressure and Temperature) Adapter** – A brass “T” assembly with a 1/4” NPT threaded end, a compression fitting for the temperature probe and a Quick Disconnect for the Pressure fitting.
10. **Field Meter Pressure Adapter** – An “L” shaped brass pipe fitting with a 1/4” NPT threaded end and Quick Disconnect end that serves as a pressure-dampening device.
11. **Instrument Drive (ID) Pulser** – A small, aluminum, rectangular box with two 90 degree angled metal feet protruding from the underside, and an L-shaped shaft that extends down between the two metal feet. Included with the ID Pulser are two mounting clamps.
12. **ID Pulser Cable** – A cable with a 5-pin connector at either end.
13. **Expandable Hole Plug** – A device used to seal off unused openings in the Blower manifold depending on options ordered.
14. **Cam Lock Cap** – A cam type cap to close off inlet of unused meter(s).
15. **Hose Plug** – A cam type plug to seal hose end.
16. **Prover Hose** – A flexible, ribbed hose with quick disconnects at each end.
17. **Personal Computer (not included)** – A laptop is required for operation of Prover. See Minimum Requirements on page 8 for necessary specifications.

Inside Accessory Case (All Provers)





18. **Controller** – An aluminum or steel rectangular box with a 6 in. finned heat sink on the side of the box and a number of sockets for electrical and computer connections.
19. **Blowers** — Devices attached to the Prover cart, responsible for producing a source of airflow during Prover testing.
20. **Master Meter(s)** – The reference meter (tertiary standard) with known performance characteristics that is traceable to national and international standards. The Prover may be purchased with one or two Master Meters.
21. **Master Meter Cable** – A cable containing a 6-pin connector at each end.
22. **Master Meter Junction Box** – A rectangular box mounted to the end cover of the Master Meter(s).
23. **Throttle Valve** – An electrical actuator used to aid in the flow rate control for the prover.

1.4 Optional Accessories:

- Optical Scanner
- ROOTS 8C Meter Test Hardware Assembly
- ROOTS Series B3 Field CTR Pulser (MTR must be “Pulser Ready”)
- Acoustic Filter
- Inverter
- 3" Quick-disconnect Connector (Female)
- 3" Quick-disconnect Connector (Male)
- SmartProve™ Cable
- USB Serial Port Converter Kit

1.5 Theory of Operation

The Prover operates as a transfer test. The meter under test (Field Meter) registers volume and compares it to the volume registered by a Master Meter. Blowers are used to pull a vacuum, which draws ambient air into the Field Meter and through a connecting hose directly into the Master Meter.

In the normal test set-up, the mass of air passes through the meter under test and then through the Master Meter. Since the Master Meter's characteristics are known, the meter under test can be characterized based on the difference in its performance parameters as compared to the Master Meter. This difference in performance is expressed in terms of accuracy (proof and percent error are also displayed).

1.6 Precautions

- No copies of this disk or any of the information contained there on shall be used for any purpose other than to operate the Model 5 ROOTS Prover.
- Do not operate the Model 5 ROOTS Prover in the presence of flammable gas or an explosion may result.
- Do not operate the Model 5 ROOTS Prover in the rain or while standing in water in order to avoid a potential electrical shock.
- Check upstream and downstream blocking or bypass valves to ensure that they operate properly and are leak tight in the closed position before powering any device.

- **CAUTION:** Purge all Field Meters (Conventional Meter Proving) of gas prior to testing. At NO time should power be applied when the Prover is in a possibly explosive atmosphere. Observe all company safety rules, regulations, and procedures.
- If the ROOTS Model 5 Prover is equipped with both the 2M and 10M or the 5M and 20M Master Meters, make certain that the unused Master Meter has the inlet quick-disconnect nipple capped or plugged to prevent any possibility of overspeeding the unused Master Meter.
- (10M/80M ROOTS Model 5 Prover only) Never connect the 10M Master Meter directly to the female quick-disconnect coupling of the 10M Blower Manifold when the 80M Master Meter is being used.
- The majority of commercial computers/laptops are designed for an office environment. Refer to your computer's reference manual for specific operating information and specifications. Refer to the Care/Proper Handling of Diskettes or CDs in the Help Directory.
- When entering Drive Rate and Test Volume during the configuration of a Meter Test, you must enter proper values. If the correct Drive Rate is selected from the screen, only valid Test Volumes are displayed. If "Other" is selected in either the drive rate/pulses/test, or the test volume selections, it is up to you to enter the proper values.
- (All Provers except 10M & 2M/10M). If "Restart" is pressed during a test, the Prover may restart the main blower with the main valve partially open. If this occurs, a sudden surge of air may apply undue stress to both the Master and Field Meters. Press "Stop" first. Stop the test and allow the main valve to close fully before pressing "Restart."
- When testing ROOTS intermittently integrated Temperature Compensated (TC) Meters, make certain to double the standard Pulses/Test value. This is due to the requirement of the special routines for testing ROOTS Meters to count transitions instead of pulses. One up and one down transition equal one pulse.
- Controlled software should only be used with the 20M.

1.7 Specifications (excluding Computer)

	Mobile 5	2M/10M	5M/20M	10M/80M
System Accuracy (excluding meter under test)	+/- 0.55%	+/- 0.55%	+/- 0.55%	+/- 0.55%
System Repeatability (excluding meter under test)	+/- 0.15%	+/- 0.15%	+/- 0.15%	+/- 0.15%
Ambient Operating Temp.				
Master Meter	+32° to +140°F 0° to +60°C	+32° to +140°F 0° to +60°C	+32° to +140°F 0° to +60°C	+32° to +140°F 0° to +60°C
Controller, etc	-4° to +140°F -20° to +60°C	-4° to +140°F -20° to +60°C	-4° to +140°F -20° to +60°C	-4° to +140°F -20° to +60°C
Ambient Storage Temp.				
Master Meter	-40° to +140°F -40° to +60°C	-40° to +140°F -40° to +60°C	-40° to +140°F -40° to +60°C	-40° to +140°F -40° to +60°C
Controller, etc.	-40° to +185°F -40° to +85°C	-40° to +185°F -40° to +85°C	-40° to +185°F -40° to +85°C	-40° to +185°F -40° to +85°C
Humidity	up to 95% non-condensing	up to 95% non-condensing	up to 95% non-condensing	up to 95% non-condensing
AC Power				
Blower	120 or 240 VAC ±15%, 48 - 62 Hz	120 or 240 VAC ±15%, 48 - 62 Hz	5M 120 or 240 VAC ±15%, 48 - 62 Hz 20M 220 VAC ±15%, 48 - 62 Hz 1-Phase	10M 120 or 240 VAC ±15%, 48 - 62 Hz 80M 230 VAC ± 10% 50 or 60 Hz, 3-phase 460 VAC ± 10%, 50 or 60 Hz, 3-phase
Electronics	120 or 240 VAC ±15%, 48 - 62 Hz	120 or 240 VAC ±15%, 48 - 62 Hz	120 or 240 VAC ±15%, 48 - 62 Hz	120 or 240 VAC ±15%, 48 - 62 Hz
Blower Capacity				
Single	0 - 7,200 ACFH at 10 inch differential 0 - 200 m³/h at 25 millibar differential	0 - 7,200 ACFH at 10 inch differential 0 - 200 m³/h at 25 millibar differential	0 - 7,200 ACFH at 10 inch differential 0 - 170 m³/h at 25 millibar differential	0 - 14,400 ACFH at 10 inch differential 0 - 400 m³/h at 25 millibar differential
Dual		0 - 14,400 ACFH at 10 inch differential 0 - 400 m³/h at 25 millibar differential	0 - 22,000 ACFH at 10 inch differential 0 - 623 m³/h at 25 millibar differential	0 - 80,000 ACFH at 20 inch differential 0 - 2265 m³/h at 50 millibar differential
Compliance	Meets FCC Part-15 requirements NMI and NIST traceable	Meets FCC Part-15 requirements NMI and NIST traceable	Meets FCC Part-15 requirements NMI and NIST traceable	Meets FCC Part-15 requirements NMI and NIST traceable
Test Medium	Air	Air	Air	Air
Test Flow Rate	5M Master Meter 35 - 5600 ACFH 1-158 m³/h	2M Master Meter 35 - 2300 ACFH 1 - 65,1 m³/h 10M Master Meter 100 - 10,000 ACFH 2,83 - 283 m³/h	5M Master Meter 35 - 5600 ACFH 1 - 158 m³/h 20M Master Meter 200 - 20,000 ACFH 5 - 566 m³/h	10M Master Meter 100 - 10,000 ACFH 2,83 - 283 m³/h 80M Master Meter 1600 - 80,000 ACFH 45 - 2265 m³/h
Inverter Requirements (Additional installation components may be required)	2000 Watts	2000 Watts	5000 Watts	N/A
Safety Rating	Complies with Underwriters Laboratory Requirements			

2. Installing the Model 5 Prover Software

2.1 Minimum System Requirements

The following criteria must be met in order to install and run the Prover software:

- One available RS 232 serial port.
- Microsoft® Windows ME, Windows NT® 4.0 Service Pack 3 (SP3), Windows 2000, XP or Windows Vista Business Edition
- Pentium 200MHz processor with 32 MB of RAM
- 256 color video with 800 x 600 capability
- 100 MB of free hard disk space

2.2 Compatibility Issues

1. Output Compatibility

The program will output test reports in a comma delimited text file format (the various data fields are separated by commas). Therefore, any program capable of reading this type of format will be able to view and manipulate the data easily and effectively.

2. Hardware Compatibility

Due to a vast number of personal computers to choose from, it has not been feasible for ROOTS Meters & Instruments to test all makes, models, or versions of PCs for operational compatibility with the Model 5 ROOTS Prover software. Dresser ROOTS Meters & Instruments has successfully tested the Prover software on a large number of well known, major brand name computers as well as non-major brand name PCs. Of those computers tested and currently utilized by ROOTS Meters & Instruments and many of our customers, the majority have functioned perfectly, provided they met our recommended minimum requirements (listed in the above Section 2.1).

ROOTS Meter & Instrument Division does not guarantee all computer brands and models will run the Model 5 Prover Software without encountering problems. Before making a final purchase from your local computer supplier, inquire about their return policy, limitations, and restrictions. We recommend a limited trial policy that offers a money-back guarantee or exchange should the purchased computer not work with the Prover software.

2.3 Software Installation

Place the software CD in the CD drive. On-screen instructions will appear directing you through the Prover software installation. Additionally, follow the instructions for installation of the LabVIEW™ run-time engine. If Autorun is not enabled, first select Prover Setup.exe on the CD drive.

NOTE:

If the infrared communications option is active on the serial port chip, there may be communications errors during the operation of this software. See the computer owner's manual for deactivation of this option.

NOTE:

It is recommended that the FIFO settings for the serial port are enabled and the settings for the applicable com port are as follows:

Port	Base I/O Address	IRQ
COM 1	3 F8	4
COM 2	2 F8	3
COM 3	3 E8	4
COM 4	2 E8	3

Also the FIFO communication speed adjustments should be on the lowest settings. This can be reached by going to Control Panel:Ports:Com Port Settings.

2.4 Verifying the Proper Files Are Loaded

For each Master Meter available for use with the type of ROOTS Model 5 Prover that is currently being used, read the identification tag attached to the Master Meter(s). Verify that the serial number for each Master Meter matches the serial number displayed in the initial start up screen of the ROOTS Model 5 Prover software. If one of the serial numbers does not match the appropriate serial number on the screen, the original factory diskette (or a copy of it) must be obtained in order to replace the current factory preset file(s). These file names are P2M.SET, P5M.SET, P10M.SET, P20M.SET and/or P80M.SET and must be copied into the same directory as the current Prover Software is located, which should be the \\Program Files\Dresser Inc\Model 5 Transfer Prover\Config Files\subdirectory. The Startup disk should have the same serial number(s) written on the disk label to match the serial number(s) of the Master Meter(s) on the Prover.

If the installation is a software upgrade and the disk label does not have serial numbers on the disk then the preset files must be located and put in the same location as the new program files. During the installation process the location of the new program will be evident. Following is a list of the configuration files that must be copied to the new location; they are based on the style of Prover that you are using.

Common files for all prover sizes:

- calidate.cfg, calibr.cfg, and MasterMeters. key

and specific files depending on prover size:

- 2M/10M Model 5 Prover: P2M.SET, P10M.SET
- 10M only Model 5 Prover: P10M.SET
- 20M only Model 5 Prover: P20M.SET
- 5M/20M only Model 5 Prover: P5M.SET, P20M.SET
- 10M/80M Model 5 Prover: P10M.SET, P80M.SET
- 80M only Model 5 Prover: P80M.SET

3. The Startup Screen and Help

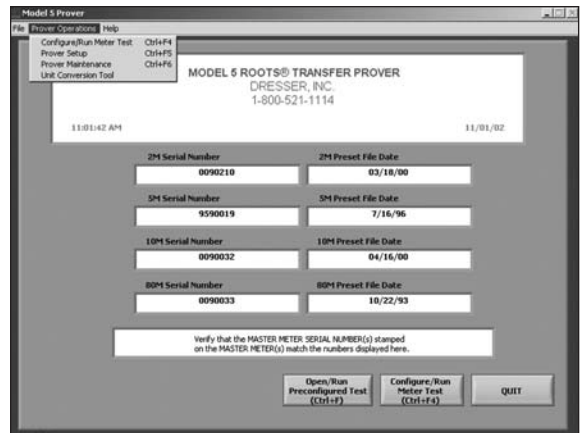
3.1 The Startup Screen

The first screen that is displayed when the program is opened is the Startup screen. From this screen, you can access the key interfaces of the Model 5 Prover software. The instructions for accessing the various functions of the Prover software will use the Startup screen as a departure point.

- Open/Run Preconfigured Test (<Ctrl+F>)
- Run File Conversion Program
- Report Manager
- Configure/Run Meter Test (<Ctrl +F4>)
- Prover Setup (<Ctrl+F5>)
- Prover Maintenance (<Ctrl+F6>)

Before proceeding to any of the above screens, make sure that the serial number on the Master Meter identification tag matches the serial number that is entered on this screen.

Also displayed is the date of the most recent preset file configuration.



3.2 The Help Directory

The Help pull down menu in the Main Screen toolbar contains two Help functions: **CONTEXT HELP** and **DOCUMENTATION**. Clicking on Show Context Help <Ctrl+H> activates a feature which permits you to receive detailed help information for any command or dialog box. Move the mouse over any displayed term and a detailed explanation of that term appears on the screen. To turn off Context Help, click on the X key in the upper right hand corner of the Context Help box.

- Pressing <Ctrl+F1> pulls up the HELP Documentation.

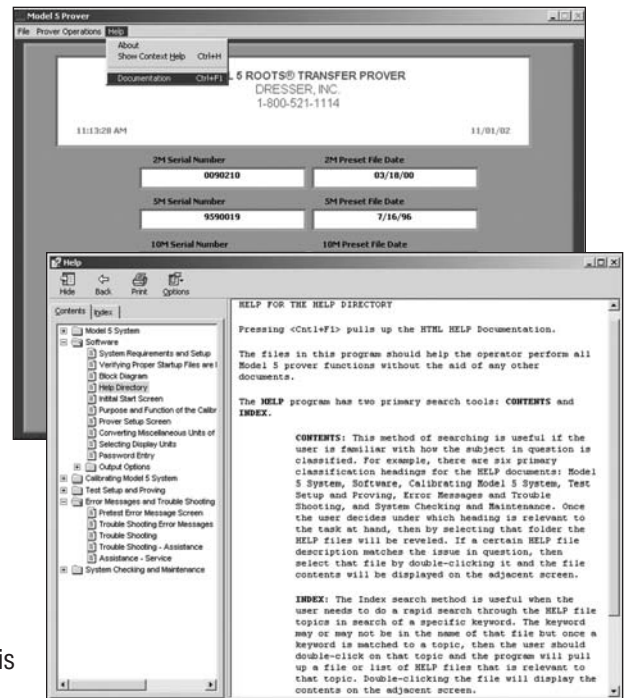
The files in this program should help you perform all Model 5 prover functions without the aid of any other documents.

The **HELP** program has two primary search tools: **CONTENTS** and **INDEX**.

CONTENTS: This method of searching is useful if the user is familiar with how the subject in question is classified. For example, there are six primary classification headings for the **HELP** documents: Model 5 System, Software, Calibrating Model 5 System, Test Setup and Proving, Error Messages and Trouble Shooting, and System Checking and Maintenance. Decide which heading is relevant to the task at hand, then select that folder to reveal the **HELP** files on that topic. If a certain **HELP** file description matches the issue in question, then select that file by double-clicking it and the file contents will be displayed on the adjacent screen.

INDEX: The Index search method is useful when the user needs to do a rapid search through the **HELP** file topics in search of a specific keyword. The keyword may or may not be in the name of that file but once a keyword is matched to a topic, then the user should double-click on that topic and the program will pull up a file or list of **HELP** files that is relevant to that topic. Double-clicking the file name displays the contents on the adjacent screen.

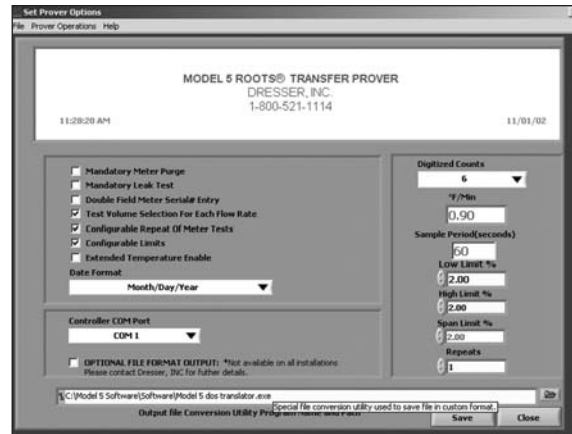
Any **HELP** file document can be printed by clicking on the Print icon at the top of the window.



4. Setting Prover Options

4.1 The Set Prover Options Screen

The Set Prover Options screen may be accessed from the initial Startup screen. At the top left of the window, click on Prover Operations and select Prover Setup (<Ctrl+F5>). The Set Prover Options screen is protected by a Level 1 password. The factory installed password is ROOTS, in all capital letters. From this 1st level password-protected menu, you can enable the following functions by checking the box next to the option. Leaving a box unchecked will disable that function.



NOTE: Any changes made must be saved prior to exiting or changes will be lost. Changes made will only affect test(s) configured after changes are saved. Any previously saved test(s) will be unaffected.

- 1. Mandatory Meter Purge:** Checking this option will force you to run a meter purge before initiating an accuracy test (See 10.5 Meter Purge).
- 2. Mandatory Leak Test:** This option requires a system leak test to pass before an accuracy test can be initiated (See 10.4 System Leak Test).
- 3. Double Field Meter Serial# Entry:** This option allows the user to input two meter serial numbers for each test report.
- 4. Test Volume Selection for Each Flow Rate:** This enables change of test volume for each flow rate if desired. If this option is not selected, then the test volume will default to the volume entered in the Test Volume Box for every flow rate. (See 5.5 Test Volume).
- 5. Configurable Repeat of Meter Tests:** Check this option to allow the selection of a different number of repeats for each test point up to a maximum of 2 repeats (3 total tests). Not selecting this option will default to the entry in the Repeats box on the lower right portion of the Set Prover Options screen. (See 5.9 Selecting Repeats).
- 6. Configurable Limits:** This option will allow the limits to be configurable for each flow rate when the test is being configured. Not selecting this box will cause the limits to default to the numbers entered in the high limit percent and low limit percent on the left portion of the Set Prover Options screen.
- 7. Extended Temperature Enable:** Check this option to allow the Prover system to operate beyond the standard temperature limitations.
- 8. Date Format:** Choose between two different date formats that will be shown on the screens and on test reports. Month/Day/Year or Day/Month/Year.
- 9. Controller COM Port:** Choose which Controller COM setting will work best with your computer setup.
- 10. Digitized Counts and °F/Min:** This configurable value is the maximum allowable temperature change before the system assumes temperature stability. The greater the number, the greater the allowable range in temperature fluctuation before the Prover test will initiate.
- 11. Sample Period:** This is the time span between temperature measurement samples.
- 12. Low Limit:** This configurable Pass/Fail limit is the maximum allowable deviation below 100%.

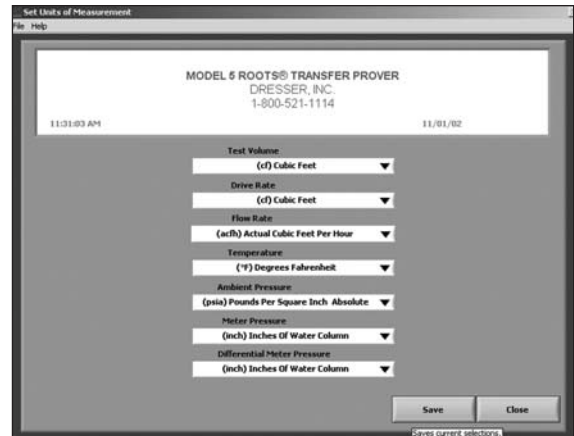
13. **High Limit:** This configurable Pass/Fail limit is the maximum allowable deviation above 100%. For example, if the Low Limit % is set to 2.00 and the High Limit is set to 1.00, then any test result accuracy falling between 98.00% and 101.00% will yield a 'Test Pass' indication, while any test accuracy result outside these limits will yield a 'Test Fail' indication.
14. **Span Limit:** This test limit defines the maximum allowable difference between the highest accuracy reported and the lowest accuracy.
15. **Repeats:** This number indicates a default number of tests that will be run in addition to the original test. A selection of 0 here will result in one test, while a selection of 1 repeat will result in 2 tests. Up to a maximum of 2 repeats.

4.2 Changing Units of Measure

Click on Prover Operations at the top of the Set Prover Options screen and select Set Units of Measurement (<Ctrl+F4>). Change the display units for any of the factors listed by clicking on the arrow in the box below it and selecting the desired unit.

Whatever unit of measurement that is chosen for Test Volume will also apply to Drive Rate (the two always have the same units of measure). The Meter Pressure selection determines which units of measure will be used for the Base Pressure entry field of a test configuration just as the Temperature selection determines the units of measure for the Base Temperature.

Once the display units have been selected, click Save at the bottom of the window to implement the changes. To restore the factory installed settings, click on File at the top left of screen and select Factory Defaults (<Ctrl+F>).



4.3 Editing Passwords

From the initial startup screen, select Prover Setup from the Prover Operations drop-down menu (<Ctrl+F5>). The factory installed Level 1 password is ROOTS, in all capital letters. From the Set Prover Options screen that appears, select Edit Passwords from the File pull down menu (<Ctrl+E>). The factory installed Level 2 password is DRESSER, in all capital letters.

LEVEL 1 PASSWORD: The LEVEL 1 PASSWORD restricts access to the PROVER SETUP and UNITS OF MEASURE screens.

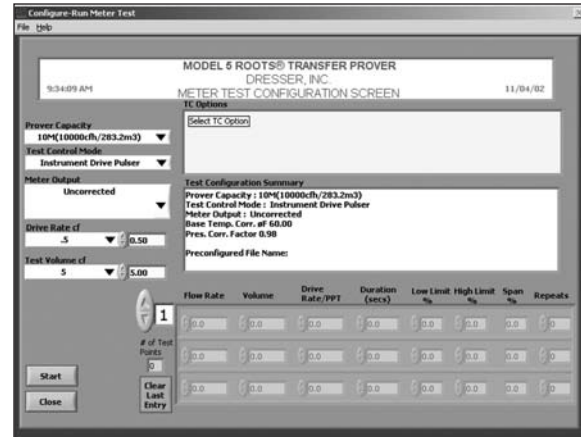
LEVEL 2 PASSWORD: The LEVEL 2 PASSWORD restricts access to the PASSWORD MENU and CALIBRATION screen.

ENTERING PASSWORDS: Any single keyboard number or character may be used as part of a password. The maximum total number of characters in a password is 20. The passwords are case sensitive. A mix of capital and or lower case letters may be used to generate different passwords.

When you enter a password to gain access to a password-protected menu, you must type the password exactly. This includes no extra key presses and no corrections. The keystrokes must match exactly what was entered for the LEVEL 1 or the LEVEL 2 PASSWORDS at the time they were last entered in the Edit Password window. One exception to the above rule: pressing the <ENTER> key without first typing some other key generates a password of twenty "space" characters. When an operator wishes to access a password protected menu, pressing the <ENTER> key once or the <SPACE BAR> twenty times will be accepted as a correct password and allow you access to the password-protected menu. If you forget or lose your password, Dresser ROOTS Meters & Instruments in Houston, Texas has the MASTER Password that will allow access to any password-protected menu. Refer to 11.3 Assistance & Service Procedure.

5. Configuring a Meter Test

From the Startup screen, access the Configure-Run Meter test screen by going to the Prover Operations drop down menu and selecting Configure/Run Meter Test (<Ctrl+F4>). You may also get there by clicking the Configure/Run Meter Test button at the bottom of the screen. From the Configure/Run meter Test screen you will set the parameters for and initiate the meter test to be conducted. Once the test information is entered, press the Start button at the bottom left of the screen to initiate the test sequence using the configured testing parameters. The information for the test configuration will stay current until they are changed or the screen is returned to the Startup screen.



NOTE:

You can press <Ctrl+F2> on your keyboard or click on the Close button at any time to cancel a test configuration and return to the Startup screen.

5.1 Prover Capacity

Click on the black arrow in the right-hand side of the box to display the drop down menu. Select the appropriate Master Meter for the test. The 2M Master Meter is a 2300 cfh capacity meter or 65.1 cubic meters. The 5M Master Meter is a 5650 cfh capacity meter or 160 cubic meters, 10M equates to 283,2 cubic meters, 20M equates to 566,3 cubic meters, and the 80M equates to a 2265,3 cubic meter capacity.

The Master Meter Cable and the Flexible Hose must be properly connected to the selected Master Meter before continuing. Refer to the appropriate Help Directory selections for the type of test being performed and/or for connecting your size of Prover, and if applicable for connecting the type of meter to be tested. Older Provers that have not had the 2M Master Meter recertified since the increase from 2000 acfh to 2300 acfh will not be able to run higher than 2000 acfh unless recertified.

5.2 Test Control Mode

Test Control Mode determines what will control the starting and stopping of a test. Click on the black arrow in the right-hand side of the box to display the drop down menu. Select the Test Control Mode to be used for the test from the following three options:

- **Instrument Drive Pulsar** testing utilizes an Instrument Drive (ID) Pulsar unit or the B3 Counter Pulsar unit.
- **Optical Scanner** testing utilizes an optical scanner or pulse unit.
- **Manual Start/Stop** testing utilizes a manually operated push-button switch.

If you choose Instrument Drive as the Test Control Mode, refer to Table 1 for the correct Drive Rate.

NOTE:

Never use partial revolutions as erratic proofs may occur.

If you choose Optical scanner as the Test Control Mode, refer to Table 2 for the correct Pulses/Test (PPT).

Important: The Pulses/Test must be a whole number, not a fraction.

If you choose Manual Start/Stop, as the Test Control Mode, neither Drive Rate nor Pulses/Test is required for test configuration.

Table 1. Drive Rates for TEST CONTROL MODE = ID

Meter Output	Meter Sizes with English Units of Measure		Meter Sizes with Metric Units of Measure		
	8C-11M	16M-102M	8C-3M	5M-38M	56M-102M
UC	10	100	0,1	1,0	10,0

NOTE: *Temperature compensated ROOTS® Meters cannot be tested using the ID Pulser.*

Table 2. Pulse/Test for TEST CONTROL MODE = OPTO

Meter Output	Meter Sizes with English Units of Measure			Meter Sizes with Metric Units of Measure			
	8C-11M	16M	23M-102M	8C-3M	5M-16M	23M-38M	56M-102M
UC	T.V.	$\frac{T.V.}{10}$	$\frac{T.V.}{10}$	100 x T.V.	10 x T.V.	10 x T.V.	T.V.
TC	400	400	N/A	400	400	N/A	N/A

T.V. = Test Volume

5.3 Meter Output

Meter Output determines what will control the mode of operation to be used for a test. Click on the arrow at the right of the box to display the drop-down menu. Select from one of the following modes of operation:

- UC (Uncorrected): No correction is made for temperature or pressure. If using an Optical Scanner for test control, it will read the non-comp volume dial.
- TC (Temperature Corrected): A correction is made for temperature. If using an Optical Scanner for test control, it will read the Temperature Compensated Volume odometer dial.
- PC (Pressure Corrected): A correction is made for pressure. If using an Optical Scanner for test control, it will read the pressure Corrected Volume dial.
- PCTC (Pressure and Temperature Corrected): A correction is made for both pressure and temperature. If using an Optical Scanner for test control, it will read the Pressure and Temperature Corrected volume dial.

If you choose TC or PCTC additional information will appear in the window labeled TC Options. Use the mouse and highlight the desired item on the list. TC Options are described below.

TC options, when English units of measure are the default, include the following:

- Diaphragm TC: Click on Diaphragm TC when testing a diaphragm meter.
- ROOTS Mechanical TC: Click on ROOTS Mechanical TC when testing a ROOTS Meter that is smaller than a 16M size.
- 16M Only ROOTS Mechanical TC: Click on ROOTS Mechanical TC when testing a 16M175 ROOTS Meter.
- ROOTS Electronic VTC: Click on ROOTS Electronic VTC when testing the ROOTS VTC.
- ROOTS Electronic IMC: Click on ROOTS Electronic IMC when testing the ROOTS IMC.

The TC options, when metric units of measure are the default, include the following:

- Diaphragm TC: Click on Diaphragm TC when testing a TC diaphragm meter.
- ROOTS Mechanical TC: 8C-3M – Click on ROOTS Mechanical TC when testing a ROOTS 8C, 11C, 15C, 2M or 3M meter.
- ROOTS Mechanical TC: 5M-16M – Click on ROOTS Mechanical TC when testing a ROOTS 5M, 7M, 11M or 16M meter.
- ROOTS Electronic VTC: Click on ROOTS Electronic VTC when testing the ROOTS VTC.
- ROOTS Electronic IMC: Click on ROOTS Electronic IMC when testing the ROOTS IMC.

If you choose TC or PCTC for meter output, the box labeled “Base Temp. Corr. °F” will appear. Manually enter the desired base temperature, then press <Enter>. Using the default units of measure, the acceptable range of temperatures is 32°F to 80°F (0°C to 30°C).

NOTE:

Test results may be affected below 40°F (4°C).

5.4 Drive Rate or Pulses Per Test (PPT)

HELP:

Refer to Configuring Tests for additional information on selecting proper values for the Drive Rate and Pulses/Test

If you select the Instrument Drive (ID) Pulser as the Test Control Mode, the box labeled Drive Rate of will be displayed on the Configure-Run Meter Test screen. Drive Rate is the volume of gas that passes through the meter for each revolution of the ID Pulser. The Drive Rate usually corresponds to the odometer's base increment. It is typically specified on the drive, the meter, and/or the device mounted to the instrument drive unit. See Table 1 on page 14 for ROOTS® Rotary Meter Drive Rates.

NOTE:

Never use partial revolutions as erratic proofs may occur.

Displayed values for Drive Rate have a corresponding valid Test Volume value(s) for the particular Master Meter being used. However, use of the Optical Scanner as the Test Control Mode requires you to calculate, enter or select valid entries.

If you select the Optical Scanner option as the Test Control Mode, the Pulses/Test box will be displayed, instead of Drive Rate. When the optional Optical Scanner is used for a meter test, you must determine the total pulses that the Optical Scanner will send back to the Controller for the entire test's duration. If a fractional number is entered into the Pulses/Test box it will be rounded up to the nearest whole number. See Table 2 on page 14 for ROOTS® Rotary Meter Pulses/Test Values.

An entire test's duration is from the start of the test until the first "Test # Complete" message is displayed on the Meter Test screen. A basic relationship exists between a Field Meter's gear ratio and its measured volume or its odometer's base increment. The odometer's base increment typically corresponds to the meter's Drive Rate, for meters with no Instrument Drive unit. If both the gear ratio and the odometer's base count are known, the proper whole number for the Pulses/Test and the proper Test Volume may be determined.

Changing the Drive Rate or Pulses/Test

For both the Drive Rate and Pulses Per Test, click on the black arrow on the right-hand side of the box to display the drop down menu. Select from the default values. Choosing “Other” will allow you to manually enter the Drive Rate or PPT into the box immediately to the right and allow you to type in the new Drive Rate or PPT, or click on the up/down arrow button to change the number displayed. Press <Enter> once the appropriate value has been selected.

5.5 Test Volume

HELP:

Refer to Configuring Tests for additional information on selecting proper values for the Test Volume.

Test Volume is the test parameter that determines what quantity of air passes through a meter during testing. For a given Flow Rate, the larger the value for the Test Volume, the longer the test's duration. All tests should last for a minimum of 30 seconds.

To change the Test Volume, click on the black arrow on the right-hand side of the box to display the drop down menu. Select from the default values, or choose "Other" to manually enter the Test Volume into the box immediately to the right. You can type in the new Test Volume, or click on the up/down arrow button to change the number displayed. Press <Enter> once the appropriate value has been selected.

You can enter an unlimited number of test points during each test configuration. On the Set Prover Options screen, you may enable the Test Volume Selection for each Flow Rate option (See 4. Setting Prover Options on page 11). The software will then allow you to enter or select a separate Test Volume for each Flow Rate that is used. If you disable that option, only the first Test Volume selection/entry will be used for each Flow Rate. The Volume will default to the Test Volume entry but can be changed by entering a new value.

NOTE:

As in the "Other" option for the Drive Rate/Pulses Per Test selection, it is possible to type an invalid value. You must select a proper or valid value. You should never select a test volume that equals a partial revolution on ID meters. This will most likely result in erroneous proofs.

5.6 Base Pressure Correction

If you choose PC or PCTC for meter output, the box labeled "Pres. Corr. Factor" will appear. Manually enter the Fixed Pressure Correction Factor.

NOTE:

For accessory units which include a fixed pressure factor, the Model 5 Prover can account for this only if you multiply the calculated Pulses/Test by the fixed pressure factor value. You must use this product as the value for the Pulses/Test entered during a test configuration.

5.7 Flow Rate

Enter the desired Flow Rate for each test on the Flow Rate section of the table at the bottom of the Configure-Run Meter Test screen.

NOTE:

Flow rates must be in descending order. Start with the highest and end with the lowest.

You will receive an error message if there is a typed value not within the expected range for the current test and Prover configuration settings. This message will indicate the valid range and proper units that may be entered. Pressing an invalid key will clear the entry field and display a zero.

A single decimal point is optional when typing the values for Flow Rate. If you enter zero for a Flow Rate, the test will not be configured or run.

You can run up to three tests for each Flow Rate value. A value of '0' in the repeat column will yield one test with no repeats; a value of '2' will yield one test with two repeats.

If the Test Volume Selection for Each Flow Rate Option is enabled (See 4.1.4), the volume will default to the initial setting *but can be changed*. Ensure that the Test Volume and Flow Rate settings are such that test duration is a minimum of 30 seconds.

Important: The Flow Rate(s) should not exceed the maximum rated Flow Rate for the Field Meter.

5.8 Test Duration

This value corresponds to the amount of time estimated to run a given sample size at a specified flow rate. This value is only to show estimated test run time, which is when the word "Running" is displayed on the Meter Test screen. The complete test sequence time will be longer due to the pretest stabilization period and the post processing period.

This value is not configurable but derived from the two values of Flow Rate and Volume. When you choose one or both of these parameters and press <Enter>, this value will automatically update.

If you have selected the option to change the Volume for each Flow Rate in the Prover Options screen, you can change the test duration by changing the Volume (See section 4.1.4 Test Volume Selection for Each Flow Rate).

If a test duration is less than the recommended 30 second minimum, an error message will appear. Tests longer than 30 seconds typically result in more accurate results. This is the case with all meters, but most significantly with Temperature Compensated meters because of the cyclical nature of the meter's pulse signal; much larger sample sizes may be necessary.

5.9 Selecting the Number of Test Repeats

You may configure the number of repeats for each Flow Rate by selecting the option for Configurable Number of Repeats in the Prover Options screen (See section 4.1.5 for Configurable Repeat of Meter Tests).

- 0 – This corresponds to one test with no repeats
- 1 – This corresponds to one test with one repeat; total 2 tests at that Flow Rate.
- 2 – This corresponds to one test with two repeats; total 3 tests at that Flow Rate.

NOTE:

If you do not select Configurable Number of Repeats, the number of repeats will be fixed and default to the number entered in the Repeats box on the bottom right portion of the Set Prover Options screen.

5.10 Save, Close and Change

HELP:

Refer to Test Setup and Proving, in the Help Directory for additional information on the various types of tests in addition to testing meter accuracy.

Once you have completed the configuration of a test, you may run the test immediately by pressing the start button, or you may save, close or change the test configuration. At the end of each test or once you select Exit Test in the Run screen, the test is ended and the screen returns to the Test Configuration screen. The test's configuration information will still be current and easily modified before running another test.

Save (<Ctrl+S>) - allows you to name the test configuration and save it to the default directory. The save location can be changed if desired.

Close (<Ctrl+F2>) – will close the current screen and return the Startup screen. Any settings for a test configuration will be lost unless you save the test configuration.

Change (<Ctrl+F>) – To modify a previously saved test file, use the Open/Run Test Configuration from the File pull down menu. This will open a standard Window's file search routine and allow you to open any saved test file in any accessible directory. Once the file is opened, you can make and save changes to a new file or initiate a test without saving the test configuration.

NOTE:

Dresser Roots Meters & Instruments preconfigured tests are protected. You cannot save them using the same name in the same location. Either rename, relocate, or do both.

6. Equipment Setup

Important: Before setting up your Model 5 ROOTS Prover, it is important to review this manual for all operating and safety instructions. Read all instructions within a specific step before executing any of the actions associated with that step.

This procedure assumes that the Model 5 Prover (and associated hardware) has been unpacked from its shipping container and is ready to be properly configured for testing.

You do not have to keep the Prover Cart perfectly level when testing, but keep it as level as possible. Avoid severe tilting of the system during operation.

Isolate the Field Meter to be tested from any gas before testing. Follow all recommended and/or company safety procedures.

For safety reasons, always use positive pressure to purge the Field Meter (meter to be tested) prior to initiating a test using the vacuum test method. Failure to purge a Field Meter can result in severe personal injury and/or equipment damage. See section 10.5 for the Meter Purging Procedure.



6.1 Field Meter Setups

1. Position the Field Meter for testing. Make sure that there are no loose objects or litter in front of the air intake; it functions as a vacuum during testing, and foreign material may be drawn into the Prover.

2.1 Setup for the 10M or 2M/10M

Connect the 25 ft. flexible Prover Hose to the outlet of the Field Meter and connect the other end of the hose to the inlet quick-disconnect nipple of the appropriate Master Meter. Where possible, put a loop in the hose between attachments to lessen pulsations between the Master Meter and the Field Meter.

Ensure that if the Prover has two Master Meters, the Hose Cap is firmly attached to the inlet quick-disconnect nipple of the unused Master Meter. For Model 5 Provers with only a single 10M Master Meter, install the Expander Hole Plug in the open end of the vertical section of the 2 in. pipe (blower manifold) located between the Blowers and the 10M Master Meter.

2.2 Setup for the 5M (Mobile 5)

Connect the 12 ft. flexible Prover Hose to the outlet of the Field Meter and connect the other end of the hose to the inlet quick-disconnect nipple of the Master Meter. Where possible, put a loop in the hose between attachments to lessen pulsations between the Master Meter and the Field Meter.

2.3 Setup for the 20M or 5M/20M

Connect the 25 ft. flexible Prover Hose to the outlet of the Field Meter and connect the other end of the hose to the inlet quick-disconnect nipple of the appropriate Master Meter. Ensure that if the Prover has two Master Meters, the Hose Cap is firmly attached to the inlet quick-disconnect nipple of the unused Master Meter.

2.4 Setup for the 10M/80M

Connect the 8 or 25 ft. Flexible Prover Hose to the outlet on the Field Meter and connect the other end of the hose to the inlet of the appropriate Master Meter (the 8 ft. Flexible Prover Hose should be connected to the Acoustic Filter). When using the 10M only, make sure that the Hose Cap is attached to the inlet quick-disconnect nipple of the unused Master Meter or the quick-disconnect nipple on the piping. When using the 80M only, make sure that the 25 ft. Flexible Prover Hose is connected to the quick-disconnect nipple of the Master Meter being used or the quick-disconnect nipple on the piping.

3. Ensure the pressure lines are properly connected from the Controller to the appropriate Master Meter. One end of the blue inlet Pressure Line will connect into the selected Master Meter's inlet pressure fitting and the other end connects into the inlet pressure port on the Controller (labeled IN PRESS). In a similar fashion, one end of the black outlet Pressure Line will connect into the selected Master Meter's outlet pressure fitting and the other end connects into the outlet pressure port on the Controller (labeled OUT PRESS).

CAUTION:

Electrical power to the Model 5 Prover must be off.

4. If not already factory connected, connect the Master Meter Cable to the appropriate Master Meter Junction Box for the Master Meter being used. Connect the other end of the Master Meter Cable to the connector labeled MASTER METER on the Controller. See page 3 and 4 for the Master Meters and their attached Junction Boxes.
5. Connect the 12 pin Field Meter Junction Box cable connector to the mating 12 pin connector labeled FIELD CABLE on the Controller.
6. Install the P&T (Pressure & Temperature) Adapter into the inlet pressure port for rotary and diaphragm meters and at the outlet pressure port for turbine meters.
7. Install the Field Meter Pressure Adapter into the outlet pressure port of the Field Meter for rotary and diaphragm meters.
8. Insert the Field Meter Temperature Probe into the P&T Adapter's vertical port until the Temperature Probe is in the center of the air stream - then hand tighten the compression fitting. If installing the P&T Adapter into the top of a diaphragm meter, do not to extend the probe to the point where it will engage with the tangent linkage. If opening is not available, install probe in the pipe line as close to meter outlet as possible.

CAUTION:

Make sure that the Field Meter Temperature Probe or the meter being tested cannot be damaged due to the positioning of the Field Meter Temperature Probe. Avoid leakage at or around the P&T Adapter or Field Meter Temperature Probe.

9. Plug the end of the Field Meter Temperature Probe cable into the Field Meter Junction Box connection labeled TEMP. The Field Meter Junction Box is shown in on page 3 and 4.

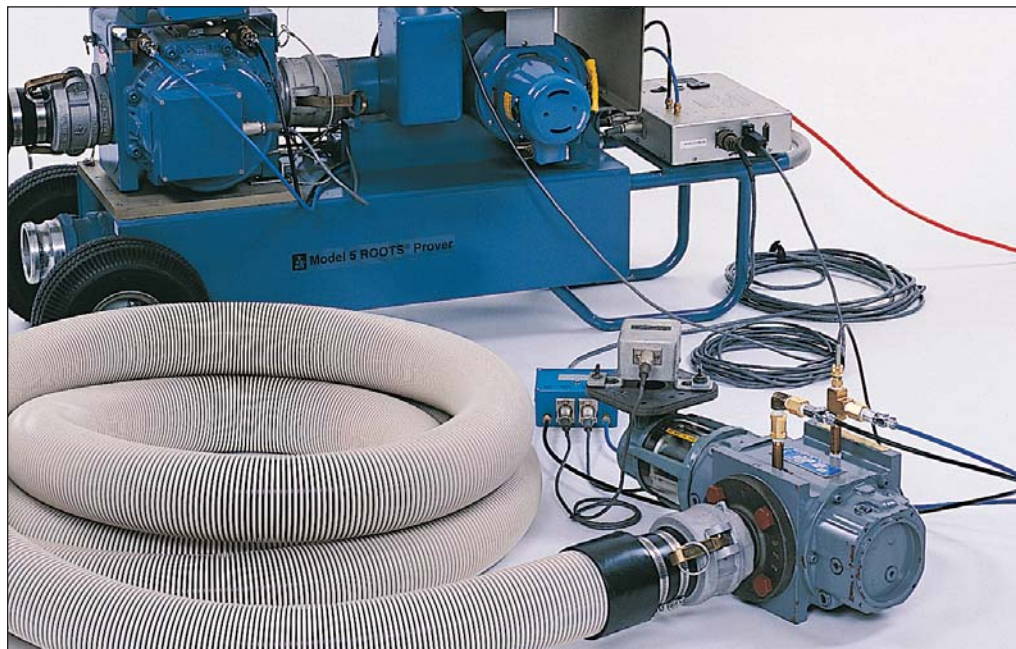


Figure 2: Instrument Drive Pulser test set-up.

10. Attach one end of the blue input pressure line to the P&T Adapter (the T-shaped brass piece) at the silver quick disconnect fitting. Attach the other end of the blue input Pressure Line to the port labeled IN PRESS on the Field Meter Junction Box.
11. Attach one end of the black output pressure line to the Pressure Adapter (the L-shaped brass piece) at the silver quick disconnect fitting. Attach the other end of the black outlet pressure line to the port labeled OUT PRESS on the Field Meter Junction Box.
12. Connect the 15-pin connector end of the Computer Cable to the Controller's connector labeled COMPUTER CABLE. The Controller is shown on page 3 and 4.
13. Connect the 9-pin connector end of the Computer Cable to the RS-232 serial port of the computer.
14. Connect the female end of the 25 ft. Electrical Extension Cord into the recessed male receptacle located on the front side of the Controller for 110 Volt Provers, or into the 220/240 Volt receptacle of the Power Transformer for 220 Volt Provers.
15. Connect the male end of the 25 ft. Electrical Extension Cord to the proper electrical supply source.

CAUTION:

For 80M or 20M Provers the Controller power requirements and large blower power requirements are different and separate. 80M Provers will require special fixed wiring for the Blower relay box. The 20M Prover will come with a special power cord for the large blower. In some cases a different plug may be needed for the 20M large blower power cord than what shipped from the factory. In any case all wiring connections should be made by a qualified electrician.

16. If using an Instrument Drive (ID) Pulser as a test control mode, perform this step then skip to step 21.

As the drive dog travels around the interior hole of the adapter plate during testing, it is critical that continuous contact is maintained between it and the follow pin. The best way to ensure that this happens is to perform the following steps a - e carefully before finally securing the ID Pulser to the adapter plate:

CAUTION:

Improper alignment and engagement of the instrument drive dog can lead to equipment damage.

- a. Place the ID Pulser over the center hole of the adapter plate. Decide which set of mounting holes in the adapter plate to use to get the ID Pulser shaft most closely centered over the adapter plate and drive dog.
- b. Fasten the ID Pulser to the adapter plate using the two mounting clamps provided. You will need to make fine adjustments to the position of the ID Pulser, so do not tighten the mounting clamps all the way down.

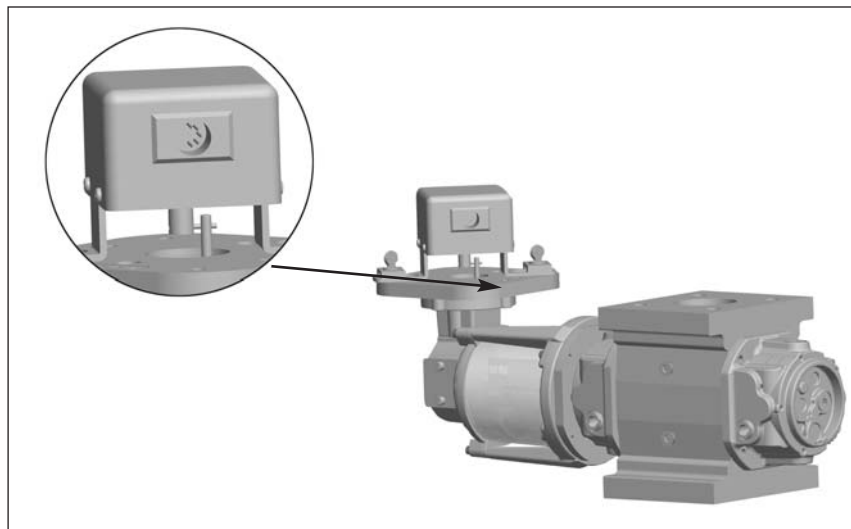


Figure 3: ID Pulser detail of drive dog to follow pin on CD Meter

- c. Using a finger, push the drive dog around the inside edge of the adapter plate hole until it is close to the ID Pulser follow pin.
 - d. Again using a finger, try to rotate the ID Pulser shaft in a 360° revolution, both clockwise and counterclockwise. If you can rotate it in a complete circle either way without the follow pin contacting the drive dog, the ID Pulser is not properly positioned. Unscrew the mounting ears and try using a different set of mounting holes on the surface of the adapter plate.
 - e. Repeat the previous step until the follow pin makes full contact with the drive dog when the ID Pulser shaft is rotated both clockwise and counterclockwise. As you rotate the ID Pulser shaft in each direction, it is best that the follow pin is blocked by the drive dog at the same point along the follow pins length. For example, if the follow pin contacts the drive dog at the midpoint of the follow pin's length when the ID Pulser shaft is turned clockwise, the same should occur when the ID Pulser shaft is turned counterclockwise.
- It is also important that the contact between the follow pin and the drive dog does not occur too closely to the end of the follow pin. This may cause the follow pin to “miss” the drive dog at some point during actual testing. Monitor a full rotation during operation.
- f. Once you are confident of the contact between the follow pin and the drive dog, tighten down the mounting ears that secure the ID Pulser to the adapter plate.
 - g. Plug the Instrument Drive (ID) Pulser cable into the Field Meter Junction Box at the connection labeled ID PULSER. The Field Meter Junction Box is shown on page 3 and 4.

17. If using an Optical Scanner as a test control mode, perform this step then skip to step 21.

NOTE:

Mounting the Optical Scanner and positioning the lens relative to the target is critical for the reliable operation of the device. Refer to your ROOTS® Optical Scanner Operations Manual for specific, comprehensive instructions on attaching the scanner to the meter and focusing the light source on the target.

- a. Align the optical scanner as indicated in Figure 5 for Series B3 (see Figures 6 and 7 for Series B2 and A1 respectively) and hand tighten. Refer to steps c and d for correct focusing and positioning.



Figure 4: Optical Scanner test set-up.

Roots Meters, Series B2 (TQM) & Series B3 (Life-lubed)

- TC Combined Test: Aim the Scanner at the dial containing 10 white and 10 black squares of the temp compensated Volume Odometer dial.
- Uncorrected Test: Aim the Scanner at the dial containing 10 white and 10 black squares of the non-compensated Volume Odometer dial or at the high-speed half black and half white dial.

NOTE:

The distance X shown in Figures 6 and 7 should be approximately 1/2 inch (or about the width of your small finger). Set angle A slightly off-center at approximately 15 degrees.

ROOTS Meters, Series A1 (LMMA)

- TC Combined Test: Aim the Scanner at the dial containing 10 white and 10 black sections.
- Uncorrected Test: Aim the Scanner at either dial that is half white and half black.

NOTE:

The distance X shown in Figures 6 and 7 should be approximately 1/2 inch (or about the width of your small finger). Set angle A slightly off-center at approximately 15 degrees.

- b. Plug the Optical Scanner cable into the Field Meter Junction Box at the connection labeled I.D. PULSER.
- c. Focus the light emitted by the Optical Scanner so that the dot displayed on the dial is of uniform brightness and that it does not cross more than one black/white boundary.
- d. Adjust the Optical Scanner amplifier to ensure that the Amplifier blinks for each transition from white-to black or black-to-white. To properly adjust the amplifier on the Optical Scanner, see the Installation and Operation manual for the scanner. If using a different Optical Scanner, follow the adjustment procedures for that specific model per the operating instructions of that scanner's manual.

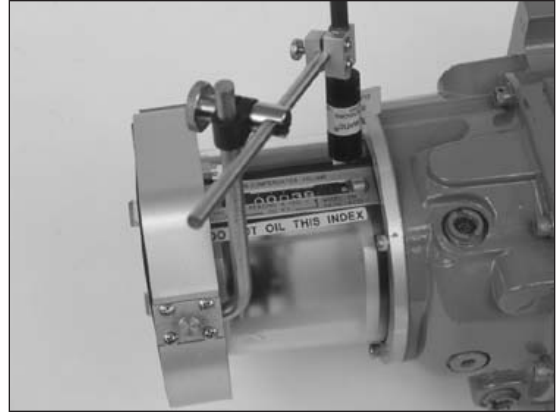


Figure 5: Optional Scanner Relative Positioning and Alignment Series B3 Accessory Unit.

- 18. If using a Manual Stop/Start Cable and Button as a test control mode, perform this step then skip to step 21.
 - a. Plug the Manual Start/Stop Cable into the Field Meter Junction Box at the connection labeled I.D. Pulser.
- 19. If using a Field Counter Pulser as a test control mode, perform this step then skip to step 21.
 - a. Attach the Field Counter Pulser to the end of the Series 3 Lexan (unit must be pulser ready). Plug the ID pulser cable into the Field Meter Junction Box labeled I.D. Pulser. Connect the other end to the Field Counter Pulser.

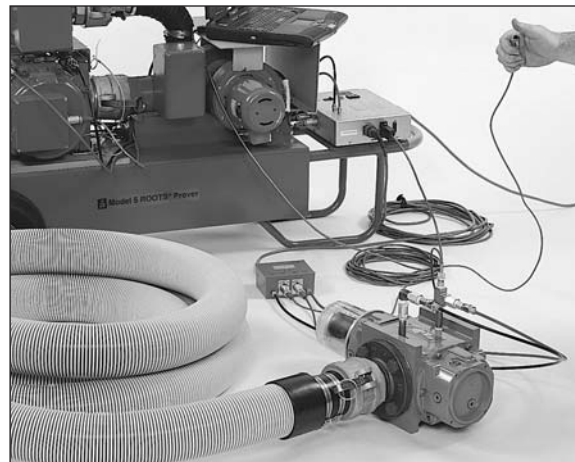


Figure 10: Manual stop/start cable set-up.

NOTE:

Set up the Field Counter Pulser by using Instrument Drive Pulser as the test control mode while configuring a test.

- 20. If using a SmartProve™ Interface Cable as a test control mode, refer to SmartProve Installation Manual
- 21. Hardware set-up is now complete. Push the Controller's power switch to the ON position and verify that the red power indicator light (located next to the power switch on top of the Controller) is illuminated. Proceed to the section entitled "Configuring a Meter Test" for the software configuration and test execution.

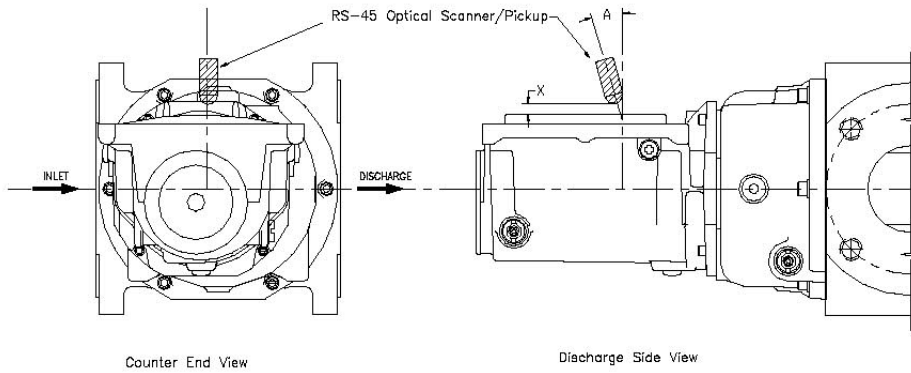


Figure 6: Optical Scanner Relative Positioning and Alignment, Series B2(TQM) Accessory Unit

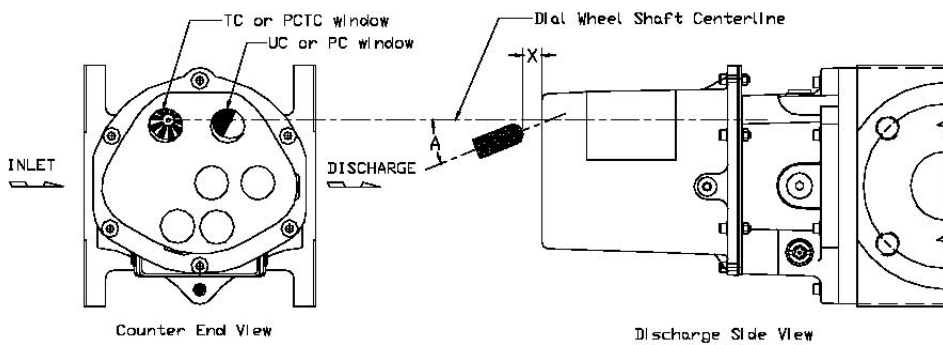


Figure 7: Optical Scanner Relative Positioning and Alignment, Series A1 (LMMA) Accessory Unit

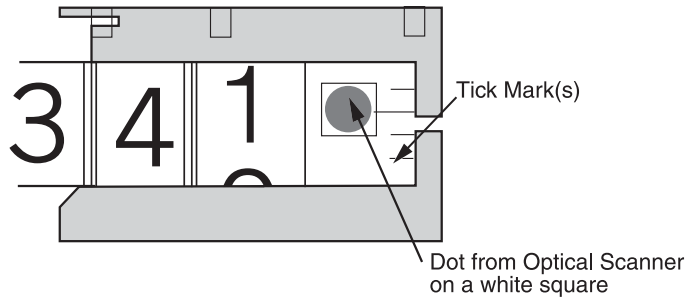


Figure 8: Volume Odometer Test Wheel Series 2 (TQM) or Series 3 (Life Lube)

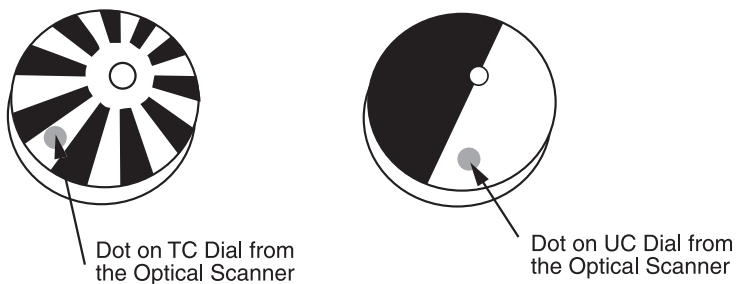


Figure 9: Series A1 (LMMA) Test Dials Optical Scanner

7. Running a Meter Test

7.1 Selecting a Preconfigured Test

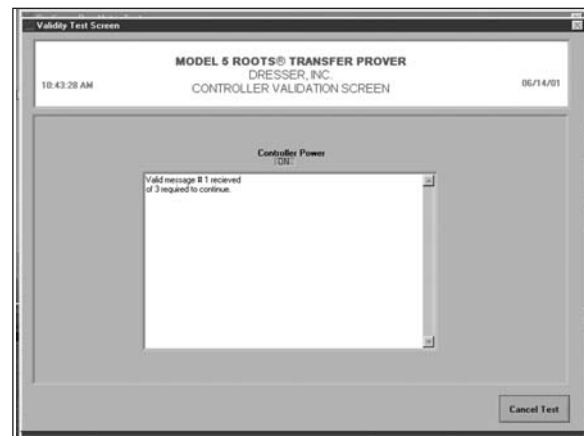
Dresser ROOTS Meters & Instruments Division has set up a wide array of preestablished test settings that you can use instead of manually configuring your own test scenario. Select an automatic test by choosing Open/Run Preconfigured Test Configuration (<Ctrl+F>) from the File drop down menu on the Startup Screen; or click on the Open/Run Preconfigured Test button at the bottom of the Startup Screen. The Configure-Run Meter Test window will appear.

By default, the contents of the Model 5 Transfer Prover folder will be displayed; double click on the folder marked Preconfigured Tests to access the Dresser ROOTS Meters & Instruments Preconfigured Test folder, which contains test settings for Series A, Series B, VCC, VTC and IMC Meters. Select the appropriate folder and double click on the file that matches the necessary test criteria. The settings will be automatically entered into their corresponding fields on the Configure-Run Meter Test screen.

7.2 The Pretest Error Message Screen

The computer makes a series of tests over a 3 second period. If any errors are detected, one of up to 11 error messages will be displayed on the screen. All error messages must be removed by correcting the problem(s) before any meter proving can be attempted. Some computers may not display the Controller Power Off error message if nothing is connected to the computer's serial port. So if the 3 second indicator does not count down within thirty seconds, perform the same checks as for the Controller Power Off error message.

Electrical shorts, shorted temperature probes, or low levels of AC input power may cause the Controller's microprocessor to stop communicating with the computer, causing data not to be received by the computer. This condition is indicated by data no longer being updated once a second during a test, or the Communication Errors message appearing in the Test Screen. It may appear as though the computer's 3 second reasonability test has ceased to count down. If the computer's serial port is not properly configured or powered this condition may occur also.



1. CONTROLLER POWER OFF will appear if any of the following conditions exist:
 - a. If 120 VAC is not plugged into the Controller
 - b. If the power switch on the Controller is not turned on
 - c. If the data cable from the Controller is not properly connected to the serial port of the computer that was selected in the Computer Setup Menu
 - d. If the serial port in your computer is not powered (see your computer's operation manual for information about using serial ports for your specific computer) Some laptops require the enabling of power to their serial and/or parallel ports.
 - e. If the cable from the Controller to the proper serial port is damaged
 - f. If your computer has a nonstandard RS-232 wiring pin out
 - g. If there is insufficient available RAM to allow the software to operate properly
2. ATMOSPHERIC PRESSURE SENSOR ERROR - The atmospheric pressure sensor is located inside the Controller housing. This error has only a few possible causes:
 - a. The calibration is corrupted.
 - b. There is a communication failure between the Controller and the laptop.
 - c. The sensor failed.

3. MASTER METER INLET PRESSURE SENSOR ERROR - Master Meter inlet and outlet pressure sensors are located inside the Controller housing and this error will appear if any of the following conditions exist:
 - a. Pressure may be trapped by the quick disconnect if it is not properly seated and locked.
 - b. The blower motors are still turning.
 - c. Pressure still remains in the pressure lines from a previous test.
 - d. The sensor failed.

Try briefly disconnecting the quick-disconnect connectors exposing them to atmospheric pressure. Wait several minutes, then press the computer's <ESC> key, reselect Configure a test and try to rezero the pressure transducers. Try turning the Controller off, wait briefly, then turn it back on again. Reselect Configure a test and see if the error message has gone away. The Master Meter's pressure sensors are checked only for a near zero reading in the absence of any moving air (blowers turned on). Do not rezero the pressure transducers just after reconnecting the pressure lines or just after the running the blowers. Refer to Pressure Transducer Rezeroing in the Help Directory for the correct procedure.

4. FIELD METER INLET PRESSURE SENSOR ERROR - The Field Meter's inlet and outlet pressure sensors are located in the Field Meter Junction Box. See MASTER METER INLET PRESSURE SENSOR ERROR above for possible causes for this error.
5. MASTER METER OUTLET PRESSURE SENSOR ERROR - Master Meter inlet and outlet pressure sensors are located inside the Controller housing. See MASTER METER INLET PRESSURE SENSOR ERROR above for possible causes for this error.
6. FIELD METER OUTLET PRESSURE SENSOR ERROR - The Field Meter's inlet and outlet pressure sensors are located in the Field Meter Junction Box. See MASTER METER INLET PRESSURE SENSOR ERROR above for possible causes for this error.

HELP:

Refer to Pressure Transducer Rezeroing in the Help Directory for the correct procedure.

7. MASTER METER TEMPERATURE SENSOR ERROR - This error appears only for the selected Master Meter used in the current test. Each Master Meter has its own temperature sensor, accessed by removing the access cover from the Master Meter Junction Box. If the Meter Cable is not connected to the Master Meter this message will appear.
8. FIELD METER TEMPERATURE SENSOR ERROR - The temperature probe for the Field Meter plugs into the Field Meter Junction Box. This error will appear if any of the following conditions exist:
 - a. Temperature Probe connector is damaged or not plugged in.
 - b. Temperature Probe cable is damaged.
 - c. Junction Box connector is damaged.
 - d. Temperature Probe is damaged.

The lowest temperature the Prover will operate at is 20°F. A warning message will appear when the temperature drops below 35 °F. An extended temperature mode has been added for customers that require the ability to test meters below freezing. Roots Meters & Instruments does not recommend operation at temperatures conducive to frost or moisture build-up in the system. Contact your Dresser Roots Meters & Instruments representative for details if required.

9. CONTROLLER DIGITIZER ERROR - This message appears if the digitizer varies by more than a few digits from the calibrated value. If the computer that was used to calibrate a specific Model 5 Prover is used with a different Model 5 Prover, this error message may appear. Make certain that the serial numbers of the Master Meter(s) match the serial numbers displayed when the Model 5 Prover computer program is first accessed. If this is true, try recalibrating the digitizer.
10. PRESSURE TRANSDUCERS HAVE NOT STABILIZED - This message will appear any time an attempt is made to restart a test before the Master Meter has had a chance to stop rotating. Wait for a short period of time and the message will clear automatically. Other more rare occasions for this error message to remain on the screen are as follows:
 - a. When testing in the pipeline, a valve is leaking.
 - b. If there are strong winds with no pressure lines connected.
 - c. The pressure line is pointed into the wind.
 - d. There is a shorted triac in the blower control circuitry (the blowers remain on whenever power is connected to the Prover).
11. METER CABLE CONNECTED TO WRONG MASTER METER - This message may appear briefly when a test is started. As long as it clears it should not cause concern. If this message appears and does not clear, the Master Meter Cable is not connected to the proper Master Meter that was configured for the current test.

7.3 The Meter Test screen

The meter test is initiated after the test has been configured properly and the automatic system check has been validated. This screen shows the system readouts as well as specifics on the Meter sensors. The test sequence will initiate once the temperature is considered stable and the flow rate has reached the set point. Pressing <Ctrl+F7> bypasses the software's testing of the rate of temperature change of the Master Meter temperature probe. The range of temperature deviation is set on the Set Prover Options screen (see 4.1.10 Digitized Counts and °F/Minute). The current mode of the test in progress can be verified by the three indicators at the middle left portion of the Meter Test screen: Temp Stable, Test Run Started, and Test Run Completed. Once the pretest criteria has been met (stable temperature and set flow), the Temp Stable indicator will turn green. This will correspond to the light on the Field Meter Junction Box turning on, signifying valid data. Once the test starts, the Test Run Started indicator will turn green and the light on the Field Meter Junction Box will start blinking.

HELP:

Refer to Temperature Stability Settings in the Help Directory for more information.

NOTE:

For optimal results, the system must not be disturbed during the pretest and testing portion of the proving cycle. There are four buttons at the bottom right of the screen that are used to control the testing process:

- Stop Test – This will stop any current test but will also allow you to reinitiate the testing with the Restart Test command.
- Restart Test – This will allow you to restart the test sequence.

NOTE:

The test will start at the flow rate selected in the Test Flows box at the bottom of the screen and will continue the test sequences for all test points at and below the selected test point.

CAUTION:

WARNING: (All provers except 10M/2M) Restarting a test using the 80M, 20M, or Mobile 5 Master Meter of the ROOTS® Model 5 Prover will allow you to restart a test before the main valve has fully closed. If the main blower starts before the main valve has fully closed, both the Master Meter and the connected Field Meter can be stressed/damaged due to the possibility of a sudden surge of air through the system. Always allow enough time for the main valve to fully close before making flow selection, or press <Ctrl+F2> prior to pressing Restart Test. This will take the user back to the Test Configuration screen and initialize the Prover.

- Exit Test – This command will stop testing and return the user to the Test Configuration screen.
- View Report – The report can be viewed at any time during and after a testing sequence, but the testing must be stopped either by issuing a Stop Test command or by waiting until the end of the test cycle. Any tests that have not been completed will show false zeroes in the test report.

The Information Box is located on the bottom right of the screen. It displays the current test information and also prompts the user for specific action, if required. The Error Box is located on the bottom left portion of the screen and displays any problems or errors that may arise (See Problem Identification and Resolution).

The Test Flows box shows the flow rates for this particular sequence of tests. This box is important when a Stop Test command is initiated. If no selection is made prior to the Restart Test command, then the test sequences will restart at the first flow entry. You also have the option to start at any other flow rate if desired; but the testing will start at the selected flow and continue for all other flows below it.

The Repeat box displays the number of times that the test will be repeated after the initial test. The number of repeats was determined when the test was configured (See section 5.9 Selecting the Number of Test Repeats).

7.4 System Readouts

1. **Ambient Pressure** – the reading of the absolute ambient pressure as read by the atmospheric pressure transducer located in the Model 5 Controller.
2. **Master Flow** – the current reading of the flow rate as indicated by the Master Meter.

NOTE:

This flow must meet the current set flow rate as indicated in the status box at the lower right portion of the screen before the test started or you will get the error message “Failure to Reach Flow Rate”.

3. **Est. Test Time(s)** – the estimated time of completion of the current test in progress. It does not indicate the total time of all the test sequences combined.
4. **Master Pressure** – the reading of the pressure at the inlet of the Master Meter as read by a pressure transducer in the Model 5 Controller.
5. **Master Differential** – the reading of the pressure drop or differential across the Master Meter as read by a pressure transducer in the Model 5 Controller (Must always be positive).
6. **Master Volume** – the current volume of air that has passed through the Master Meter for this test. Note that this is a raw number and has not been corrected with respect to Temp, Pressure, or Master Meter offset. The Model 5 system uses electronic pulses from the Field Meter to start and stop a test, therefore the final Master Volume readout is contingent on the system and Field Meter accuracies. If the system and Field Meter were both 100 percent accurate, then the Master Volume reading would match the preconfigured ‘Test Volume’ as shown on the middle right side of the Run screen.

7. **Master Meter Temp.** – the temperature of the air as read by a temperature probe inside the Master Meter.
8. **Field Meter Pressure** – the pressure at the inlet flange of the Field Meter (the meter under test). This reading comes from a pressure transducer located in the Field Meter Junction Box and connected to the Field Meter by a blue pressure tube.
9. **Field Meter Differential** - the pressure drop across the Field Meter or meter under test as read by a pressure transducer in the Field Meter Junction Box (Must always be positive).
10. **Test Volume** – the test volume that was entered during the test setup. This is the total volume run for each test.
11. **Field Meter Temp.** – the reading of the temperature probe placed in or near the Field Meter.

HELP:

*For the correct positioning of the Field Meter temperature probe, see the HELP documentation under “Connecting** Meters”.*

7.5 Calculated Values

These following displayed fields refer to the six boxes that are located in the lower left corner of the Meter Test screen.

1. % Uncorrected Proof = (Master Meter volume*/Field Meter volume) x 100
2. % Temperature Correction = [(Field Meter temperature ° R**)/ (Master Meter temperature ° R**) - 1] x 100
3. % Pressure Correction = {[(Master Meter Inlet Pressure + Atmospheric Pressure)/ (Field Meter Inlet Pressure + Atmospheric Pressure)] -1} x 100
4. % Corrected Proof = [(% Uncorrected Proof) x (% Pressure Correction + 100) x (% Temperature Correction + 100)] / 10,000
5. % Accuracy = (1/% Corrected Proof) x 10,000
6. % Error = % Accuracy - 100

The Test Pass or Test Fail indicator will light up at the end of the test. Results of the Pass/Fail conclusion are dependent on the acceptable ‘Limits’ and ‘Span’ that were input by you at either the Prover Setup screen or when the test was configured.

* Master Meter volume after being corrected by the performance Presets.

** (°R = °F + 460)

8. Test Results and Reports

8.1 Reviewing, Saving, and Printing Test Results

You can review any of the completed individual test results after the test sequence is complete or after you click on the Stop Test button. Select the test flow and the appropriate repeat number from the selection boxes which appear at the bottom center of the Meter Test screen once all tests are completed and/or the prover is stopped.

Additionally you can view, save or print test results in a test report format. From the Meter Test Screen, click on the View report button to display the Meter Test Results screen. The test report format may be customized here, by entering desired labels for the report headers such as Customer Name, Location, etc. Unless they are changed, the current labels will remain as default entries. Press the <TAB> key once the desired text appears in the entry field. If the <TAB> key is pressed before any other key, the current text displayed in the text entry field will be accepted. All entries made to the text entry fields will be retained as defaults for subsequent reports until they are changed.

Pressing <Shift+Tab> will return you to the previous field and allow you to correct any entry errors.

NOTE:

If you selected the Double Field Meter Serial Number Entry option in the Set Prover Options screen, you must type the Field Meter serial number twice and ensure that both entries match identically. If you accept the old value by pressing the <Enter> key before pressing any other keys, the second entry will also accept just the <Enter> key which causes no change to the Field Meter serial number.

Once the report headers have been filled in, you may save test sequences by clicking on the Save Report button. This will create a time-stamped Model 5 Prover file with a .DAT extension to be saved in the current Default Directory. This test report file is saved in a comma-delimited format which can be accessed from this software or any database or program capable of reading this type of file.

Print test results by selecting the Print Report button at the bottom of the Meter Test Results screen. This program can access any properly configured printer either local or via network. A printer must be configured properly, paper loaded properly, cabled and powered properly in order to generate a printed report. The printer settings can be configured in the Windows printer configuration subroutine.

To exit the Meter Test Results screen, click on the Close button to return you to the Meter Test screen.

8.2 The Report Manager

This application is used to manage the test data that is generated by the Prover. From the Main Startup screen click on file and select Report Manager, or from the Set Prover Options screen, click on Prover Operations at the top left of the window and select Report Manager.

The Folder box shows the default path and directory where the test data files are saved. This path and directory can be changed to search for test report files in other directories by clicking on the "Change" button.

NOTE:

When choosing a new directory, do not select the "Open" button but instead click on the Select Cur Dir (Select Current Directory) button.

In the Show Report box, scroll through the various search criteria using the up/down arrow button.

- All Reports - lists all the test reports in the selected folder.
- By Date - enables you to locate files generated between two dates. Enter start date [From (MM/DD)] and end date [To (MM/DD)] to narrow search to a certain time period.
- By Value - The files will be classified by one of the named fields on the test report (i.e. Location, Operators Name, Master Meter Type, etc.).

NOTE:

The entry for 'Value' is not case sensitive and the search uses an automatic wildcard at the end of the entry. Therefore, a full entry description is not usually required. Example: to search for LMM Gas Co. using the "Customer Name" query, the correct files will be found by entering the partial description "LMM".

The buttons along the bottom of the Report Manager Screen provide a variety of functions by which you may handle the meter test data:

NOTE:

Software Version 5.31 and above - printer settings permits you to change margins and fonts for printed reports.

- Printer Settings – Where you change margins and font settings used when printing test reports.

CAUTION:

Changing these Settings could adversely affect your printed report. Please use caution.

- Update List – When searching for test reports it sometimes becomes necessary to use limiting parameters to focus the search. If these parameters are used, once the search criterion has been input, select <Update List> and the list will be reevaluated using the new criteria. "Update List" will also update the names under the "Where" search criteria if changed under the "Edit Names" option.
- Print Report – This option will print the selected report.
- View Report – Once you select a report, you can view it using this option.
- Edit Names - This button will bring up the Report Customization subroutine. In this mode, you can modify all the headings for the report generation categories. Click on the 'Save' button after each and every change before selecting the 'Close' button to implement the changes. If you make multiple changes and press the Save button after the last change, only that last change will be saved. Note: If you change any of the names in the Edit Names subroutine, use Update List to update the names under the "Where" pull down menu.

For example, the default heading "Operator's Name or ID" can be modified to read "Prover Technician" on the test report.

If you select the "Close" button before the "Save" button, no changes will be implemented in the "Edit Names" subroutine.

9. Calibrating the Prover

The Model 5 Prover comes from the factory with all components calibrated and the Model 5 Prover tested as a complete system. It is recommended that the calibration be checked twice a year. Listed below are the eight components that require periodic calibration. It is suggested that all components be recalibrated at one time, but any of the components can easily be calibrated individually or in any combination.

- Atmospheric Pressure Transducer
- Master Meter Inlet Pressure Transducer
- Field Meter Inlet Pressure Transducer
- Master Meter(s) Temperature Probe
- Field Meter Temperature Probe
- Master Meter Outlet Pressure Transducer
- Field Meter Outlet Pressure Transducer
- Analog to Digital Converter Check Point

The configuration files CALIDATE.CFG and CALIBR.CFG contain the unique calibration information for each individual Model 5 ROOTS Prover. Refer to Calibration and Preset Files in the Help Index (<Ctrl + F1>) for more information on these critical files.

9.1 Reaching the Prover Calibration Screen:

1. At the upper left of the Main Menu screen, click on Prover Operations and select Prover Setup from the drop down menu, or press <Ctrl + F5>.
2. Enter the Level One password. The factory-installed Level One password is ROOTS, in all capital letters. Press <Enter>.
3. The Set Prover Options screen will appear. From the upper left of this screen, click on Prover Operations and select Calibrate Prover, or press <Ctrl + F5>.
4. Enter the Level 2 password. The factory-installed Level 2 password is DRESSER, in all capital letters. Press <Enter>.
5. The Display Calibration Dates and Constants screen will appear. Each of the eight components that require periodic calibration are listed. Next to each is shown the current numerical setting of the component - the "Calibration Constant" - and the most recent calibration date. If all current calibration settings are fine, press <Cancel> and you will be returned to the Set Prover Options Screen. If calibration of any or all of the components is required, press <OK>, and the first Prover Calibration Screen will appear.

By default, the Calibrate A/D Converter Check Point screen will appear first. Use the up/down arrows to the left of the component name to navigate through each of the individual component calibration screens. A controller error message will appear if the computer cable is not connected to the controller and/or the controller power is off.

CAUTION:

Use of a comma instead of a period in numerical entries during calibration can cause an erroneous calibration and/or a corrupted calibration file.

Figure 11
The Prover Calibration Screen

Ensure that the appropriate Meter capacity is selected before calibrating

Displays critical information that may affect calibration

The information displayed here is specific to each component's calibration screen. See Figure 12 for examples of the other displays.

Provides step-by-step calibration instructions.

Shows the last time that the component was calibrated.

Use Conversion Tools to easily calculate equivalences between different units of measure.

Figure 12
Displays for Individual Calibration Screens

This display appears only on the calibration screen for Atmospheric Pressure.

This display appears on 4 calibration screens: Master Meter inlet and outlet pressure; and Field Meter inlet and outlet pressure.

This display appears on 2 calibration screens: Master Meter temperature probe and Field Meter temperature mode

“Count” is a scaled value that represents the signal sent from the electronic Controller. This value indicates pressure or temperature, depending on the component being calibrated.

9.2 The Conversion Tool

The Model 5 Prover is always calibrated in English units of measure, but a Conversion Tool has been provided at the bottom of the Prover Calibration Screen. Use this feature to convert various commonly used units of measure to their English unit equivalents.

At the lower left of the Prover Calibration Screen is a box labeled “convert from”. Enter the value for the measurement to be converted, or use the up/ down arrows to the left of the box to increase/ decrease the displayed values. To the right of this box, choose the unit of measure from the drop-down menu. The Conversion Tool will convert from the following units: psi, inches of H²O, bar, mbar, kPa and inHg. The equivalent units of measure will be displayed along the bottom of the Conversion Tool box.

The Conversion Tool will also convert temperature readings between Fahrenheit and Celsius. Simply enter the °F or °C value to be converted in the proper box, and the program will automatically display the alternate units.

9.3 How to Calibrate the A/D Converter Check Point

HELP:

Refer to Calibration and Preset Files in the Help Index for more information (press <Ctrl + F1>).

Each Prover test is preceded by a three second verification of Prover condition, connection and operation. A Controller Digitizer Error message displayed during this test occurs when the digitized counts value has drifted by more than 5 points, indicating that recalibration of the Analog to Digital Converter is necessary.

First, check to see that the Prover cart’s Master Meter serial number matches that entered on the Main Menu Screen. If the two serial numbers are not the same, retrieve the up to two preset files, two calibration files and CD Key file from the Model 5 Prover original factory discs. These files are named P2M.SET, P5M.SET, P10M.SET, P20M.SET or P80M.SET, depending on the capacity of the Master Meter(s). For the presets, CALIDATE.cfg and CALIBR.cfg for Calibration and MASTER METERS.KEY for the CD Key.

If the serial numbers match, but the Controller Digitizer error recurs, the A/D converter must be recalibrated:

1. Verify that the Digitized Counts have stabilized.
2. To calibrate or reset the Converter, click on the <Accept> button at the bottom of the screen.
3. The Calibration Instructions window will show when the process has been completed.

The box marked Digitized Counts is a stable reference point for the Analog to Digital Converter. If the box reads zero, the Model 5 Controller is not connected properly or there is no power to the controller (see troubleshooting on page 44 or Equipment Setup on page 18).

9.4 How to Calibrate the Atmospheric Pressure Transducer

The box labeled Count indicates a digitized value that represents the amount of pressure sent from the electronic Controller. Also displayed is the current ambient pressure, which was calculated using the value from the most recent Transducer calibration.

1. In the box labeled Enter Barometric Pressure (psia) enter a value that represents the current atmospheric pressure in pounds per square inch absolute. Press <Enter>.

NOTE:

If pressure has been gauged with an instrument that uses units other than psia, use the Conversion Tool at the bottom of the screen to convert to psia units.

2. Click on the <Accept> button at the bottom of the screen to save the new calibration setting.

NOTE:

The uncertainty of your pressure standard should be less than ±0.2 psia. A greater uncertainty factor can result in a poor calibration of the Atmospheric Pressure Transducer.

9.5 How to Calibrate the Master Meter Inlet Pressure Transducer

1. Connect the Master Meter Cable to the Master Meter to be calibrated.
2. Make sure that the proper meter capacity is selected in the box labeled "Select Master Meter Type".
3. Disconnect the Master Meter's inlet pressure line from the Controller at the port labeled IN PRESS (inlet pressure). This will expose the transducer to atmospheric pressure.

NOTE:

This step is not applicable to the 80M Master Meter Inlet Pressure Transducer. The pressure line connection for the 80M is always left open to atmospheric pressure except for steps 7 and 8, below.

4. In the box labeled "Count" is a scaled value which represents the analog pressure signal sent from the electronic Controller. Once the displayed pressure reading stabilizes around zero, press <Accept> to zero the transducer.
5. Re-connect one end of the Master Meter's pressure line to the to the Controller at the port labeled IN PRESS. (This is the same line that was disconnected in step 3.)
6. Disconnect the Master Meter inlet pressure line at the Master Meter inlet pressure port.
7. Attach the pressure standard and pressure source to the disconnected end of the Master Meter inlet pressure line.
8. Use the pressure source to apply a 5.000 ± 0.05 inch water column **vacuum** to the Master Meter inlet pressure line. The reading on the pressure standard will be approximately -5.000 inches and will appear in the box labeled "Pressure (inch)". This is the current Meter pressure, and the negative value of the reading indicates the presence of a vacuum.

NOTE:

The 80M Master Meter Inlet Pressure Transducer requires a positive pressure reading (+5 inches of water column). This positive pressure applies to the open fitting that is connected to both the 80M Inlet Pressure Transducer and the 80M Chamber Pressure Transducer.

9. After the displayed reading has stabilized, click on the <Accept> button at the bottom of the screen to complete and save the recalibration.

9.6 How to Calibrate the Field Meter Inlet Pressure Transducer

1. Disconnect the pressure line from the Field Meter inlet pressure port and from the Field Meter Junction Box at the port labeled IN PRESS (inlet pressure). This will expose the transducer to atmospheric pressure.
2. In the box labeled "Count" is a scaled value which represents the analog pressure signal sent from the electronic Controller. Once the displayed pressure reading stabilizes, press <Enter> to advance to the next step.
3. Re-connect one end of the pressure line to the Field Meter Junction Box at the port labeled IN PRESS. (This is the same line that was disconnected in step 2.)
4. Attach the pressure standard and pressure source to the open end of the Field Meter inlet pressure line.
5. Use the pressure source to apply a 5.000 ± 0.05 inch water column **vacuum** to the Field Meter inlet pressure line. The reading on the pressure standard will be approximately -5.000 inches and will appear in the box labeled "Pressure (inch)". This is the current Meter pressure, and the negative value of the reading indicates the presence of a vacuum.
6. After the displayed reading on the pressure standard and the count reading has stabilized, click on the <Accept> button at the bottom of the screen to complete and save the recalibration.

9.7 How to Calibrate the Master Meter Temperature Probe

NOTE:

All Master Meters except 80M

1. Remove the four screws holding the cover plate on the Master Meter Junction Box.

NOTE:

All Master Meters

2. Connect the Master Meter cable to the Master Meter to be calibrated.
3. Make sure that the proper meter capacity is selected in the box labeled "Select Master Meter Type".
4. Remove the Master Meter temperature probe from its well. Do not disconnect any wiring.
5. Using a rubber band, attach the Master Meter temperature probe to a sensing device that will serve as a temperature standard. Immerse both into a liquid container that is already at the temperature at which the test will be conducted. Make sure that the liquid is gently stirred to equalize the temperature throughout the container.

It is important that there is no greater than $\pm 1^{\circ}\text{F}$ difference between the temperature of the liquid in the container and the testing temperature. In addition, ensure that the temperature of the liquid in the container is extremely stable and that the temperature standard has an uncertainty of no more than $\pm 0.20^{\circ}\text{F}$.

NOTE:

Before completing the next step, make sure that both the reference temperature and the value displayed in the box labeled Count have stabilized.

6. Type in the reference temperature as measured by the temperature standard, then click on the <Accept> button at the bottom of the screen.
7. The Calibration Instructions box on the screen now indicates to remove the Master Meter temperature probe and let it stabilize. Leave both the temperature probe and the temperature standard in the liquid container, and click on the <Accept> button at the bottom of the screen.

The recalibration of the Master Meter temperature probe is now complete and the new setting and current date are saved.

8. Remove both the Master Meter temperature probe and the temperature standard from the liquid container. Remove the rubber band holding them together and carefully dry both probes.
9. Re-insert the Master Meter temperature probe into its well and secure it in place.

NOTE:

All Master Meters except 80M

10. Re-attach the Master Meter cover plate and tighten all four screws.

9.8 How to Calibrate the Field Meter Temperature Probe

1. Make sure that the Field Meter Junction Box cable is connected to the Controller.
2. Connect the Field Meter temperature probe to the Field Meter Junction Box at the port labeled TEMP PROBE.
3. Using a rubber band, attach the Field Meter temperature probe to a sensing device that will serve as a temperature standard. Immerse both into a liquid container that is already at the temperature at which the test will be conducted. Make sure that the liquid is gently stirred to equalize the temperature throughout the container.

It is important that there is no greater than $\pm 1^{\circ}\text{F}$ difference between the temperature of the liquid in the container and the testing temperature. In addition, ensure that the temperature of the liquid in the container is extremely stable and that the temperature standard has an uncertainty of no more than $\pm 0.20^{\circ}\text{F}$.

NOTE:

Before completing the next step, make sure that both the reference temperature and the value displayed in the box labeled Count have stabilized.

4. Type in the reference temperature as measured by the temperature standard, then click on the <Accept> button at the bottom of the screen.
5. The Calibration Instructions box on the screen now indicates to remove the Field Meter temperature probe and let it stabilize. Leave both the temperature probe and the temperature standard in the liquid container, and click on the <Accept> button at the bottom of the screen. The recalibration of the Field Meter temperature probe is now complete and the new setting and current date are saved.
8. Remove both the Field Meter temperature probe and the temperature standard from the liquid container. Remove the rubber band holding them together and carefully dry both probes.

9.9 How to Calibrate the Master Meter Outlet Pressure Transducer

1. Make sure that the proper meter capacity is selected in the box labeled "Select Master Meter Type".
2. Disconnect the Master Meter's outlet pressure line from the Controller at the port labeled OUT PRESS (outlet pressure). This will expose the transducer to atmospheric pressure.
3. In the box labeled "Count" is a scaled value which represents the analog pressure signal sent from the electronic Controller. Once the displayed pressure reading stabilizes around zero, press <Accept> to zero the transducer.
4. Re-connect one end of the Master Meter's pressure line to the to the Controller at the port labeled OUT PRESS. (This is the same line that was disconnected in step 3.)
5. Attach the pressure standard and pressure source to the disconnected end of the Master Meter outlet pressure line.
6. Use the pressure source to apply a 5.000 \pm 0.05 inch water column **vacuum** to the Master Meter outlet pressure line. The reading on the pressure standard will be approximately -5.000 inches and will appear in the box labeled "Pressure (inch)". This is the current Meter pressure, and the negative value of the reading indicates the presence of a vacuum.
7. After the displayed reading has stabilized, click on the <Accept> button at the bottom of the screen to complete and save the calibration.

9.10 How to Calibrate the Field Meter outlet pressure Transducer

1. Connect the Field Meter cable to the Controller.
2. Disconnect the pressure line from the Field Meter outlet pressure port and from the Field Meter Junction Box at the port labeled OUT PRESS (outlet pressure). This will expose the transducer to atmospheric pressure.
3. In the box labeled "Count" is a scaled value which represents the analog pressure signal sent from the electronic Controller. Once the displayed pressure reading stabilizes around zero, press <Accept> to zero the transducer.
4. Re-connect one end of the pressure line to the Field Meter Junction Box at the port labeled OUT PRESS. (This is the same line that was disconnected in step 2.)
5. Attach the pressure standard and pressure source to the open end of the Field Meter outlet pressure line.
6. Use the pressure source to apply a 5.000 \pm 0.05 inch water column **vacuum** to the Field Meter outlet pressure line. The reading on the pressure standard will be approximately -5.000 inches and will appear in the box labeled "Pressure (inch)". This is the current Meter pressure, and the negative value of the reading indicates the presence of a vacuum.
7. After the displayed reading has stabilized, click on the <Accept> button at the bottom of the screen to complete and save the calibration.

10. Prover Maintenance

Click on Prover Operations at the top of the Startup screen. Select Prover Maintenance (<Ctrl+F6>) from the drop down menu to initiate the Maintenance screen. From this screen, you may perform several system checks that will help to ensure the best performance and safest operation of your ROOTS Model 5 Prover.

In addition to performing service tests, you can keep track of the operational hours since your Master Meter(s) were last serviced.

By default, the Prover Self Test will display first when the Maintenance screen is opened. Click on the up/down arrow keys at the left side of the Test box to scroll through and select the desired test.

10.1 Master Meter Hours of Operation

At the top of the Maintenance screen shows the hours of operation of each Master Meter. This important record can be used to monitor time periods between service functions or to initiate factory recertifications. You can reset the hours of operation by pressing <Ctrl+R> or selecting the particular readout with the mouse. This would normally be done after a Master Meter or blower has been serviced.

NOTE:

Reinstalling the software resets the hours.

The hours of operation are activated when a meter test starts (any time the blowers turn on). With your mouse, click on the appropriate Master Meter. A window will pop up asking if you are sure you want to rezero that Master Meter - click “yes” if you wish to continue. Only that Master Meter’s hours of operation will be set to zero. To zero all Master Meter hours of operation, each Master Meter’s hours must be selected and zeroed individually.

NOTE:

The hours of operation section does not take into account the speed or the cleanliness of the air or the environment with which the blowers and Master Meters must operate.

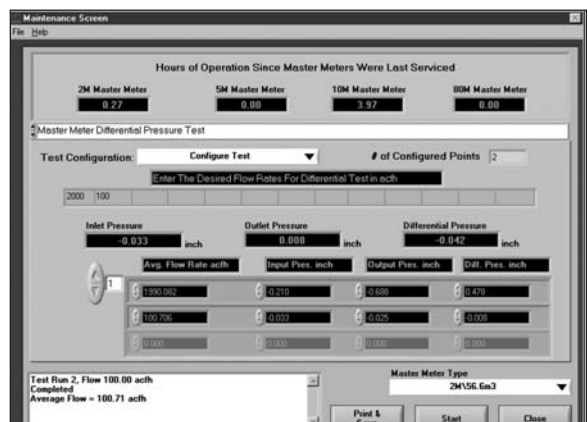
10.2 Prover Self Test

Select “Prover Self Test” from the pull-down menu under the Hours of Operation.

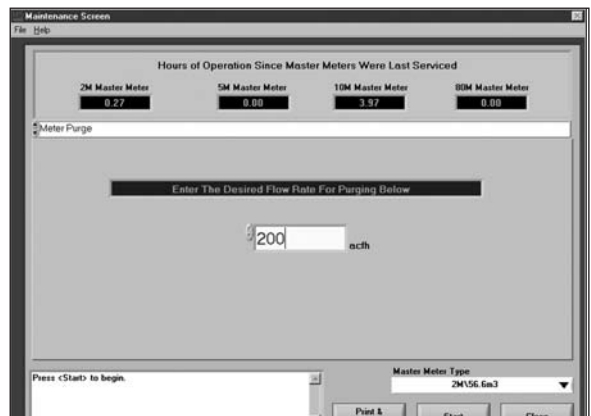
This test verifies operation of major electronic components of the Model 5 Prover: You are prompted for information to setup and start the Self Test. The Prover Self Test starts and runs a predetermined test volume at a fixed flow rate. Pressing the Close button aborts the test and returns you to the Maintenance menu. Pressing the Start button at the bottom of the screen will initiate the test sequence.



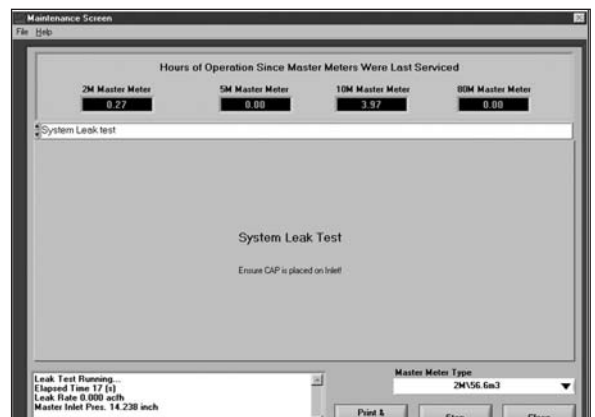
Prover Self Test



Master Meter Differential Pressure Test



Meter Purge



System Leak Test

CAUTION:

All Provers except 2M/10M: Allow time for the main valve to close prior to pressing the Start button. The Prover Self Test is a short system test. Information is sent to the Controller and a test is started with a flow rate of approximately 50 percent of the Master Meter's capacity. Specific results are expected at the end of the test. If the results of the test vary from the expected values by more than a slight percentage, a failed message will be displayed. If the test results are as expected, a passed message is displayed. This does not test the Field Meter pulser components, but the field cable must be connected to the Controller and the Field Meter temperature probe must be connected to the Field Meter junction box.

CAUTION:

The Prover hose should not be connected to the Field Meter in order to prevent any possibility of over-speeding the Field Meter.

HELP:

Refer to Prover Self Test in the Help Directory for additional information.

10.3 Master Meter Differential Pressure Test

HELP:

Refer to Master Meter Differential Pressure Test in the Help Directory for additional information.

Select "Master Meter Differential Pressure Test" from the pull-down menu under the Hours of Operation.

This test measures the differential pressure between the Master Meter inlet pressure transducer (blue 1/4" pressure line) and the Master Meter outlet pressure transducer (black 1/4" pressure line) at the entered flow rates. Normally this test is run with no hose or Field Meter connected to the Master Meter being tested.

You have the choice of running a factory preconfigured test sequence or a custom test in which you will be prompted to enter the Prover capacity and desired flow rates manually. Enter these flow rates into the row of gray boxes that runs across the screen. The test will start and display the differential pressure between the inlet and the outlet of the selected Master Meter. The differential pressures are calculated for the approximate flow rates entered during the differential pressure test's configuration and displayed on the left side of the computer's screen. Differential pressure test results are dependent on how the meter is connected.

After successful completion of the differential test, a box will appear that will signal completion. At this point you can print/save the data. The file will be stored in a comma delimited text file in the Data subdirectory under the Model 5 Transfer Prover directory that was created when this software was installed.

10.4 System Leak Test

HELP:

Refer to Leak Test in the Help Directory for additional information.

Select "System Leak Test" from the pull down menu directly under the Hours of Operation. Perform a leak test to help determine if and where a leak is present in the Prover system. Leakage during a Field Meter test will result in a lower Accuracy (higher Corrected Proof) reading than that typically expected. The volume registered by the meter under test is compared to the volume registered by the Master Meter. In an Automatic test, the Field Meter starts and stops the test according to the test volume selected in the software configuration. Perform a leak test using either the automatic vacuum test or positive pressure method.

NOTE:

Important: Place a Dust Cap over the inlet of the Field Meter and secure in place. If a Dust Cap is not available, use a mating flange and gasket, or other method that will produce an air tight seal at the opening of the Field Meter inlet.

All Provers except 80M

To configure the Model 5 ROOTS Prover 2M/10M for a leak test, connect the Prover as for testing a meter (See Equipment Set-up for the 2M/10M Prover on page18).

Select either the 10M/283.2m³ or the 2M/56.6m³ Prover capacity in the Master Meter Type drop down menu near the bottom-right of the Maintenance screen. Click on the Start button to initiate the 3-second reasonability test prior to starting the leak test. A Passed or Failed message is displayed on the computer screen, at the end of the test. The Controller will stop the test afterwards.

A Passed or Failed error message will be displayed at the end of each test. If the computer doesn't receive the single pass/fail indicator from the Controller; the blowers may stop without any messages being displayed. If this condition occurs, restart the leak test by first selecting Cancel Test and then clicking on the Start button again. If the mandatory leak test option has been selected in the Prover options menu, the leak test must Pass before any other tests may be performed.

NOTE:

Mobile 5 and 20M Provers only: Allow time for the main valve to close prior to pressing the start button.

10/80M Provers Auto leak Check

NOTE:

This method requires a compatible Controller chip to operate.

Prepare the system before initiating the auto leak test sequence by making the following preparations:

1. The Main Butterfly valve mounted next to the 56 Master Meter must be in the closed position and leak tight.
2. Cap off the 8" diameter hose that is used to connect the test meter to the large resonance tank.
3. Connect the short 6' hose from the small blowers to the 10M Master Meter.
4. Connect the 10M Master Meter to the small resonance tank.
5. Connect the long 24' hose from the other end of the small resonance tank to the T connection right next to the 56M Master Meter.

Select the 10M/283.2m³ Prover capacity in the Master Meter Type drop down menu near the bottom-right of the Maintenance screen. Click on the Start button to initiate the 3-second reasonability test prior to starting the leak test. The test will run for approximately 4 minutes before a Passed or Failed message is displayed on the computer screen. The Controller will stop the test after approximately 4 minutes. A Passed or Failed error message will be displayed at the end of each test.

If a leak is detected, then start with a fewer number of components in your test loop until the leak test passes; then systematically add one component at a time until you track down the leak.

The leak test sequence will apply a vacuum to the system for 4 minutes and in the last 8 seconds will monitor the movement of the 10M impellers. An average frequency of 2Hz at -16" W.C. for the 10M meter is the maximum allowable leak rate.

NOTE:

The 80M can also be leak tested using a manual test where you simply pressurize the system and check for pressure loss.



10.5 Meter Purge

Select “Meter Purge” from the pull-down menu under the Hours of Operation.

Warning: *An explosion may occur if the Prover is operated in the presence of explosive or flammable gases. Always purge the Field Meter and all associated piping prior to running any test. The Prover is not intrinsically safe.*

The Field Meter and associated piping may be purged of all flammable gas with a hand-held blower or by using the blowers on the Model 5 Prover. Observe any and all applicable company safety procedures and rules for purging the meter and piping.

If the blowers on the Prover will be used for purging the Field Meter and associated piping, connect as follows:

All Provers except 80M

NOTE:

If the Prover has two Master Meters, make certain the quick-disconnect nipple cap is plugging the unused Master Meter's inlet quick-disconnect nipple.

1. Isolate/remove the Field Meter from the gas line and allow any released gas to dissipate. The Field Meter must be open to atmosphere at both the inlet and the outlet.
2. Install a quick-disconnect nipple in the piping on the inlet side of the Field Meter, or directly to the inlet of the Field Meter if the Field Meter has been removed from all piping.
3. Connect one end of the flexible hose to the single exhaust/outlet male quick disconnect nipple that is marked “Purge”. For the 10M and 20M Provers, the exhaust is located at the end of the tank. For the Mobile 5, the exhaust nipple is part of the single blower assembly. Connect the other end of the flexible hose to the quick disconnect nipple installed at the inlet side of the Field Meter. The outlet of the Field Meter must be open to the atmosphere so as to allow air to flush any gas from the meter and any associated piping.
4. Observe all company safety procedures and rules for purging meters, and make the proper connections listed above. Place the Model 5 Prover as far from the Field Meter as possible. Place the exhaust from the Field Meter as far as possible from the Prover's blowers. The software must be configured for a meter purge, which is accomplished in either of two ways. Refer to Prover Setup in the Help Directory for information about the Mandatory Meter Purge Option. The other method is to configure a Meter Purge from the Maintenance Menu. Select Prover Maintenance (<Ctrl+F6>) from the Prover Operations drop down menu, then select Meter Purge. Select the appropriate Master Meter type from the drop down menu near the bottom right of the screen. Enter the single flow rate at which to purge the meter into the box in the middle of the screen. Click on the Start button to activate the blowers for the meter purge.

NOTE:

Important: Do not over-speed the Field Meter.

5. Allow the meter and the associated piping to purge for the required period to remove all flammable gas from the piping and the vicinity of the Model 5 Prover.
6. Select Stop to stop the blowers once the piping, meters, hoses, and the immediate area are clear of gas.

10.6 Maintenance Recommendations

To maintain a high standard of accuracy for your ROOTS Prover, we recommend the complete proving system be returned to the factory for Remanufacture & Recertification using one or more of the following criteria:

1. As dictated by State regulatory agency or Company procedure.
2. Every three to five years, depending upon prover system condition and frequency of use.

3. Check the Master Meter differential against the original factory differential curve supplied with the new or recertified Master Meter. As long as the differential remains within the limit of 1.0" w.c. at 50% of flow (10,000 acfh) of the value shown on the original curve, the meter accuracy is considered unchanged. For the 5M, the differential should not exceed 0.5" w.c. at 50% of flow.
4. Return the Master Meter to the factory for Remanufacture & Recertification if any of the following conditions are applicable: The differential does not meet the criteria in item #3 (above) at any time or after completing the recommended maintenance procedures, or reference Meter tests results consistently exceed $\pm 0.5\%$ as compared to the original curve.

10.7 Maintenance Check List

Master Meter Inlet Screen

Inspect the Master Meter inlet screen prior to each test.

1. Use a vacuum cleaner to remove debris.
2. Always remove the screen from the Master Meter before cleaning with solvent or attempting to clean by blowing with air through the screen.

Master Meter(s)

Visually inspect the impellers for damage and dirt build-up a minimum of once each month.

1. Remove from the Prover Cart before cleaning.
2. A clean, lint free cloth may be used to wipe contamination from the impellers.
3. Do NOT use any type of solvent to flush dirt from the Master Meter.
4. Blow clean, dry compressed air through the Master Meter.

P&T Adapter and the Field Meter Pressure Adapter and All Master Meter Pressure Adapters

Check at least once a month for dust, moisture or contamination.

1. Seal the non-quick disconnect end of the Adapter(s).
2. Apply a pressure of 10 inches of water column to the quick disconnect end of the Adapter(s).
3. Quickly open the sealed end of the Adapters and record time.
4. Record the time when the pressure in the previously sealed end is equal to ambient pressure.
5. If the time between steps 4 and 3 is less than two (2) minutes, the Adapter is in good condition. If the time is greater than two (2) minutes, replace the Adapter.

Reference Meter Testing

1. Use a Reference Meter as a standard to monitor the prover system for changes that could affect test results. The documented history of performance is the baseline for continuous comparisons.
2. When inspecting and characterizing the performance of the Master Meter(s), compare and plot the results against the historical baseline with an acceptable tolerance (i.e., $\pm 0.55\%$).
3. Perform the Reference Meter test on an occasional basis (weekly, monthly, etc.) to ensure proper prover system condition and repeatability. Run tests any time Field Meter tests are consecutively out of tolerance or you suspect problems.
4. The Reference Meter should be inspected and its performance characterized at least once every six (6) months by an independent verification agency to ensure the proper operation of the Model 5 Prover.

CAUTION:

Unplug the extension cord from the Controller.

NOTE:

The following Blower Inspection Instructions do not apply to the large blowers for the 20M or 80M Provers. Those blower motors should be inspected and maintained by fully trained and qualified personnel.

Blowers

1. Inspect the tightness of the Blower armature brush caps at least once every three (3) months. Carefully re-tighten the brush caps if they are loose, or replace. Switch blower plug connection to the controller once a month to ensure equal wear on both blower brushes.
2. Inspect the armature brushes for wear at least every 400 hours of operation, or as required by apparent changes in sound and arcing. A significant increase in heat can be generated by brushes less than 1/2 inch in length, increasing current and resulting in a premature failure of the blower(s).
3. Remove brush and measure length of square carbon. it should be 1/2" or longer. If not it must be replaced.
4. Install the brush.
5. Re-attach the armature brush caps.
6. Exchange #1 blower to #2 blower each month for averaged usage on the main blower #1.

CAUTION:

Turn the Controller power "OFF" and remove Master Meter(s).

7. Turn each Blower off by moving its individual power switch to the "OFF" position.
8. Unplug each Blower power cord from the Blower ports (labeled "BLOWER 1" and "BLOWER 2") on the Controller.
9. Plug each Blower power cord (one at a time) into a 120 VAC electrical power source.
10. Turn the corresponding Blower power switch to the "ON" position.
11. The Blower motor bearings are good if the motor sounds "smooth".
12. Repeat the above steps (1 through 11) for the other Blower.

Prover Cart**10M Only**

1. Check the air pressure in the Prover Cart's tires at least once a year. Maintain tire pressure at 30 psig.

All Provers

2. Clean the frame, wheels, tool box, and exterior surfaces of the Master Meter(s) with a damp cloth and compressed air, as needed.
3. Inspect the inside of the Silencer(s) at least once every three (3) months for obstructions and loose noise absorbing material.
4. Inspect all cables for frays. Replace as required.

Accessories

1. Inspect all flexible hoses, caps, and plugs for damage. Replace as required.
2. Clean the quick-disconnect couplings once every three (3) months using a degreaser. If the quick disconnect is removed from the Master Meter, apply a thin film of aluminum anti-seize compound on the male threads before reinstalling.
3. Once a month, inspect all electrical cables for damage and to ensure that the connectors are clean and pins/contacts are straight.
4. Inspect the Instrument Drive (ID) Pulser for damage prior to and after each use.
5. Inspect the Optical Scanner for damage prior to and after each use.

11. Problem Identification and Resolution

11.1 Common Operation Problems

1. Prover doesn't stabilize at the proper Flow Rate

For 2M/10M, 10M portion of 80M Systems

The most likely cause would be a problem with the valve mechanism. Some examples of this include a sticking solenoid, valve, or valve linkage; a worn, damaged, or improperly adjusted valve linkage; or an obstruction in the valve, valve piping, meter(s), silencer, or hose(s). A malfunction by the Blower or the Blower's Controller may also be the cause. For suspected Blower problems, try swapping the Blower power cords where they connect into the Controller. Try turning the Controller off and then back on to reset the electronics. Then reconfigure or reselect the test settings, restart, and rerun the test. Flow Rate surging is typically due to insufficient back pressure in the system, which causes the valves to open too far. Blowers at maximum power usually means that there is a restriction somewhere in the system or that the solenoid-operated butterfly valve is not opening properly.

For Mobile 5M, 20M/5M and 80M portion of 10M/80M Systems

The most likely cause is a malfunction in the motorized gate valve, slip clutch, or gear reduction mechanisms. Turning the power switch off and then back on causes the Controller to energize the valve positioning motor to close the gate valve. The slip clutch must not slip until the gate valve is fully closed. Once the valve closes, the slip clutch should slip for several seconds.

2. One or more of the Blowers comes on without initiating a test

The Blower(s) are controlled by the electronics in the Controller. If one of the triacs controlling the Blower(s) operation shorts or leaks, the Blower may start or run faster than it is supposed to. Usually turning the Controller off, waiting a few seconds, then turning it back on will correct the problem. If the problem persists, contact the factory for assistance.

3. The test stops shortly after the Blowers start (the Blowers start and then stop almost immediately)

If the Controller gets no indication that the Master Meter's impellers have started rotating, the Controller will stop the test once the Blowers start. No error messages appear but the test ends with no indication other than that the Blowers have stopped. This commonly occurs after a Leak Test when you forget to remove the seal at the inlet of the Field Meter or upon initial start up if the shipping seals have not been removed from the Master Meter(s) and the air exhaust(s) port. It could also occur if debris or trash restricts air flow or locks up the Master Meter. Insufficient power can also cause this problem.

4. The Prover software or the computer locks up

If this happens, make note of where and how the malfunction occurred and what keys were pressed. Be able to describe exactly what appeared on the screen before and after the problem occurred. Try turning the computer and the Controller off, wait several seconds, and turn both of them back on again; then attempt to duplicate the problem. Make certain that at least 32 megabytes of RAM memory are available to the Prover software. Try opening other software programs that are installed on the computer (for example a spreadsheet or a word processing program) to verify that the computer is fully functional. If the computer itself does not appear to be the problem, try reinstalling the Prover software from the original disk (or the backup of the original disk). If the problem persists, contact the factory for assistance. Refer to Getting Assistance/Service in the Help Directory.

5. Accuracy is out of specification

The accuracy will not be what it is supposed to be if the Field Meter needs servicing. Factors that affect the accuracy of a transfer prover include the length and volume of the hose, elbows, and transitions; the size and interaction between the Field and Master Meters; where the pressures and temperatures are measured; and the stability of the testing environment. Pressure pulsations commonly occur when transfer testing Field Meters. These pulsations or resonant points can be rather pronounced at certain flow rates under otherwise normal operating conditions. You can minimize the effects of these resonant points by increasing or decreasing the flow rate slightly. Acoustical filters are available to reduce or eliminate the effects of pulsations and resonance. Contact the factory for details.

6. Accuracy varies when conducting outdoor meter testing

An unstable operating environment can have a noticeable effect on meter test results. The most common effect can be seen when testing meters outside in direct sunlight. The sun's warmth can heat the air traveling through the Flexible Hose so that by the time the air reaches the Master Meter, an increase of 20 degrees Fahrenheit is quite possible. The Master Meter may remain very close to the ambient air temperature and change only very slowly, while the temperature of the air traveling through the Flexible Hose fluctuates rapidly as clouds, wind, and/or shade affect it. The measured Master Meter temperature, even though situated in the center of the air stream, may not exactly match the actual temperature of the measured volume inside the Master Meter's measuring chamber. You can reduce these effects significantly by shading the Flexible Hose and insulating it as much as possible from dramatic temperature changes above or below ambient conditions.

11.2 Troubleshooting Error Messages

1. "FAILURE TO REACH FLOW RATE"

This error appears in the upper right corner of the test screen if the Controller has not reached the configured flow rate within a specified amount of time after the Master Meter temperature has stabilized. Possible causes are that the Blower(s) are not turned on or plugged into the Controller; or that there is a restriction in the piping, meters, the silencer, or the Flexible Hose(s). Check and clean the screens at the inlet of the Master Meter(s) regularly. Problems with the valves, the valve solenoid, or valve linkages may also generate this error. Make sure the connector plug from the valve solenoid is attached into the Controller at the connector labeled THROTTLE VALVE. Notice what the displayed flow rate actually is to determine whether or not a problem exists. The appearance of this message does not prevent the start of a test, nor does it necessarily mean there is a problem with the Prover. It merely indicates that it took longer than the typical amount of time to reach the desired flow rate.

2. "CAUTION: TEST DURATION BELOW RECOMMENDED 30 SECOND MINIMUM"

This message displays any time a meter test is configured and/or completed where the test duration is less than 30 seconds. It is merely a reminder that the best results are obtained using tests that are configured to run for at least 30 seconds in duration. The test data is sampled once each second, so a test lasting at least 30 seconds yields better results than tests of a shorter duration.

3. “WARNING”

This message appears under any one of the temperature or meter pressure transducer displays in the Meter Test Screen. If this error displays it means that the transducer's output exceeded the “normal” limits of the transducer's operation. If more than one Flexible Hose is connected between the Field and Master Meters, or if a restriction in the hose develops, etc., this message will appear. This is only an indication that a problem may exist, not that a transducer has failed. Once this message appears, it does not go away until the next configured test starts or until the current configured test is restarted. The test continues, and the results are calculated using the averaged test data regardless of the appearance of the message. Refer to Pressure Reasonability Settings in the Help Directory for additional information. Contact the factory for assistance if necessary.

4. “FATAL ERROR”

This message appears under any one of the temperature or meter pressure transducer displays in the Meter Test Screen. This message will appear when the transducer's value, immediately above the displayed message, is beyond the operable limits of the individual transducer. Once the message appears it forces the termination of the current test. You must correct the condition before proper operation of the system may resume. Contact the factory for assistance if necessary.

5. “COMMUNICATION ERRORS #”

This message displays during the running of a test. The software monitors the data transmissions from the Controller to the computer. If for any reason even one of these one-second interval data transmissions is not received or is not processed properly, this message will appear in the middle of the screen. The message will remain on the screen, through the up to 6 individual test runs, until the software clears the currently displayed screen. The message appears and remains even if only one transmission was not processed out of hundreds. Occasional displays of this message can be considered acceptable. The test can continue and it should complete normally; however, Dresser recommends repeating tests where this message has appeared. Missed data transmissions that occur during an actual test will advance the error message's counter, while the duration counter is incrementing. Data transmissions that occur outside of an actual test merely display the error message but do not increment the error message's counter. One out of 30 transmissions should not affect the results significantly. If the error message appears frequently, the source of the problem should be identified and corrected. Contact the factory for assistance.

NOTE:

Read the file named ‘System Requirements and Setup’ to insure that the proper parameters and configuration variables are being used.

6. “A/C INPUT FREQUENCY TO HI/LOW”

This message appears whenever the supply power's frequency varies beyond specified limits. The warning message goes away automatically once the problem is no longer detected by the Controller's electronic circuitry. This problem typically appears when generators are used as the Prover's power source.

11.3 Assistance & Service Procedure

To provide you with the best possible service, we ask that you follow our Assistance and Service Procedure prior to requesting detailed technical assistance with the Model 5 ROOTS Prover product line. If you have a question of a general nature, simply call 1-800-521-1114 and the operator will connect you with the best qualified, available individual to answer your question. This information helps Dresser Roots Meters & Instruments by allowing us to identify and track potential problems/resolutions to improve both existing and future products. It also helps you, our customers, because it provides us with specific information required by our engineers and technicians to identify and resolve your questions/problems as thoroughly and efficiently as possible.

If detailed assistance/technical information is likely to be involved, please fill out the 2-page Assistance and Service Procedure form prior to making the call for help. This form is included with the Model 5 ROOTS® Prover software and can be printed out from the Maintenance screen. Press <Ctrl+F6> from the Startup screen to access this screen, and then select Print Service Request Forms from the File drop down menu. Make certain the printer is ready before sending the form to the printer.

The most critical portion to be filled out on the Assistance and Service Procedure form provides a detailed description of the problem(s). Include the test parameters; the prover options that were enabled for the test(s); the units of measure; warning messages; and any other visual or audible abnormalities which may have occurred. Pay particular attention to all warning, error, and status messages displayed on the computer's screen. If such a message appears on the screen, write the message down word for word as it appears. If the problem is related to test data, save and/or print the test data for our inspection.

Actual test reports are often very helpful in identifying Prover problems. Copies of the Master Meter's preset files may also be required (P2M.SET, P5M.SET, P10M.SET, P20M.SET, P80M.SET, calidate.cfg, calibr.cfg, and MasterMeter.key).

If the problem appears to be related to how the software functions on your computer, specifics about your computer may be needed. If you are uncertain about how to answer specific questions listed under the Computer/Software section of the Assistance and Service Procedure form, consult the user's manual for your computer and/or your computer dealer. Save the answers for possible use in the future.

Once the Assistance and Service Procedure form has been prepared, call 1-800-521-1114. You will be transferred to the most qualified, available person to assist you.

11.4 Return Authorization Procedure

A complete copy of the Return Authorization Procedure is available from the factory.

NOTE:

Important: *Products returned without authorization may be subject to delayed inspection and servicing. It is difficult to identify intermittent problems unless our technicians know specifically what to look for, such as symptoms, procedures, etc.*

After filling out the Assistance and Service Procedure form, and then seeking assistance from the Customer Service Department at Dresser Roots Meters & Instruments, it will be determined whether all or part of a Prover is to be returned to the factory. A member of the Customer Service Department will provide you with a return authorization number. Please fill out the form titled Product Return Tag, which is also printable from the Maintenance Menu screen. Attach both pages of the Assistance and Service Procedure form to the completed Product Return Tag. Include both forms or copies of both forms with the packaged items to be returned.

NOTE:

Important: *Dresser is not responsible for damage or loss due to improper packaging of returned articles.*

Appendix

A. Measurement Uncertainty of the ROOTS Model 5 Prover

In meter testing, it is important to understand the realities of measurement accuracy and acceptable system error. This is commonly referred to as measurement uncertainty. The American National Standard for Rotary Type Gas Displacement Meters, ANSI B109.3, PART VII, Test Methods and Equipment, 7.2 Measurement Reference Base states: "The final authority for all standards of measurement in the United States is the National Institute of Standards and Technology (NIST) ..." Part VII, 7.5.3 Accuracy addresses "Accuracy of Test Standards," "Uncertainties of Observations," and "Uncertainties in Method of Test." This often over-looked subject is an important component of measurement standards, test equipment and test methods. Part VII, Test Methods and Equipment, 7.6 Calibration of Meter Testing Systems, 7.6.1 General, second paragraph states: "Meter testing systems shall be calibrated when first installed, and following alterations, damage or repairs which might effect accuracy. To assure that the accuracy of the meter testing systems is maintained on a continuous basis, a daily leakage test shall be made and a periodic accuracy indication with a test meter of known accuracy shall be made. If the test results differ by more than ± 0.5 percent from the test meter accuracy, the cause of the error shall be determined and necessary corrections made prior to reuse of the system."

Secondary test devices such as Bell or Piston type provers traceable to NIST are recognized by the Natural Gas Industry as having an accuracy of $\pm 0.25\%$. These provers are used to establish the accuracy presets for a transfer prover Master Meter – a tertiary test device (third removed from NIST traceability). The accumulated errors of all three standards, as well as the errors of the associated equipment must be considered when analyzing meter test results.

What does this mean? A test could result in an indicated meter accuracy of 101.25% and still be considered accurate and within specification. How? By adding in the uncertainty of the prover. A prover testing at the high end of its accuracy band ($\pm 0.55\%$) and a meter testing at the higher end of its specification (i.e., 100.7%) would have a combined theoretical error of + 1.25% ($100.55 \times 100.7 + 100$).

As recommended by ANSI, a test meter of known accuracy (Reference Meter) should be used in problem identification and resolution. A factory-certified accuracy curve is supplied with each ROOTS reference meter. To characterize the performance of the Transfer Prover System, a reference meter should be tested on the prover and the test results then plotted and/or compared against the historical baseline data. This is best method for a quick prover operational check and verification of repeatability.

Errors associated with measurement of pressure, temperature and flow rate contribute to the overall uncertainty of the testing process. Assuming that all factory recommended test procedures are followed, the test environment is within the specified tolerances, and all associated equipment is in proper working order - the overall uncertainty of the Prover system can exceed the system design or specified accuracy. A significant reduction in uncertainty can be accomplished by: (1) calibrating the equipment under the conditions that it will be used during testing; (2) ensuring that the test points do not correspond to a flow condition that would cause resonance; and (3) by using larger test volumes.

NOTE:

It is extremely important that the meter to be tested is stored (soaked) for a minimum of eight hours in the stable environment in which the testing will be conducted. Meter soaking and test environment stability allow the probe well temperature to equalize to the temperature of the air flowing through the meter. Significant increases in uncertainty (greater errors) can occur if the meter is not properly conditioned prior to testing or if the test environment is not stable during testing. During field testing, consideration must be given for the induced errors due to unstable or averaged temperatures during a test sequence.

The ISO Guide method for calculating measurement uncertainty should be used to determine the total overall uncertainty.

Appendix

B. TC Unit Operational Check

This procedure may be used to verify the overall accuracy of the TC Unit, independent of the basic meter body measurement accuracy. The designed accuracy for the TC Unit is within $\pm 0.5\%$ of the theoretical correction for gas temperatures between -20°F to $+120^{\circ}\text{F}$ (-29°C and $+49^{\circ}\text{C}$).

NOTE:

All Series B3 ROOTS TC meters are compensated to a 60°F (15°C) Base Temperature.

The TC Unit Operational Check is based upon Calculated Measurement Counts (actual measurement) versus Theoretical Counts, using a 25 cycle count of the compensation cycle. This is the best method for determining the accuracy of the TC unit with the meter in service. By using the 25 cycle method, all of the gears in the TC unit make a complete revolution, and thus provides a greater amount of confidence in the resulting accuracy calculation. The method for determining the theoretical counts for a 25 cycle test is outlined in the "Calculating Theoretical Counts" section.

A ROOTS® Transfer Prover is a commonly used device for conducting a TC Unit Operation Check in the shop or when the meter is not in service. The prover is used for flow rate control and indication of temperature during the test procedure. The prover may also be used during this time to test the accuracy of the basic meter body using the non-compensated odometer or the RPM test wheel. The information derived from the TC Unit Operation Check is then combined with the meter's non-compensated accuracy to determine the meter's overall accuracy, including temperature compensation (basic meter body non-compensated accuracy X accuracy of TC unit = overall or combined accuracy).

Procedure for the TC Unit Operational Check

1. Measure and record stabilized gas (or air) temperature directly at the meter inlet using a certified temperature standard.

NOTE:

Inaccurate results may occur if the gas temperature is not stabilized before starting the test.

2. Record the temperature displayed by the Accessory Unit's temperature probe. The indicated temperature is visible through the accessory housing window located above the odometers. Compare to the readings taken in step 1. Both values should agree within $\pm 4^{\circ}\text{F}$.

NOTE:

The temperature indicated by the unit's temperature probe will not be used since this is an estimated reading. Use the temperature recorded in Step 1 as the reference temperature for the TC unit operational check.

3. Observe the Temperature Compensated volume odometer. When the odometer stops turning after an intermittent compensating cycle, record the last 3-digit reading (Ci) indicated on the odometer, PLUS the value indicated by the graduated marks on the test wheel. Read as a whole number. (See the Sample Counter Reading in Figure 13 below.)

NOTE:

Some of these digits may be partially or completely obscured by masking. The masking must be removed if the readings are not visible.

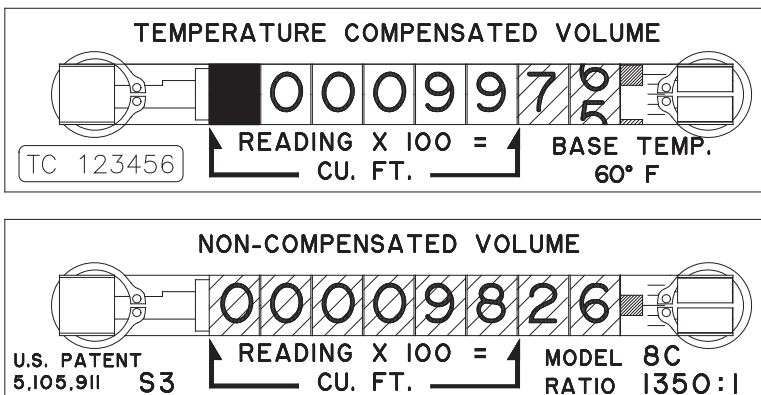


Figure 13: A reading of 9756 would be the number recorded for TC unit operational check.

4. After the Compensated Volume odometer has cycled 25 times and stopped, record the last 3 digits of the Temperature Compensated odometer (**Cf**), PLUS the graduated wheel estimation as described in Step 3 on previous page.
5. Use Table 1 (page 51) or the calculation described in the next section (Calculating Theoretical Counts) to determine the Theoretical Number of Counts (**TNC**) for the indicated temperature recorded in Step 1.
6. Calculate the percent accuracy of the TC Unit with the following equation:

$$\text{Percent Accuracy} = \frac{\mathbf{Cf} - \mathbf{Ci} \times 100}{\mathbf{TNC}}$$

Example: Assume the gas temperature is 53.0°F, and from Figure 22, the initial odometer reading (**Ci**) = 9756. We then allow the odometer to cycle 25 times and record the final reading. We will further assume the final odometer reading (**Cf**) = 2295.

NOTE:

When **Cf** is less than **Ci**, place a “1” in front of the reading for **Cf**. In this example, the adjusted reading for **Cf** would read as “12295”.

From Table 1, the Theoretical Number of Counts (**TNC**) = 2534.1.

Using these numbers in the “Percent Accuracy” formula, the accuracy is calculated as:

$$\frac{12295 - 9756}{2534.1} \times 100 = 100.19\%$$

Calculating Theoretical Counts

The number of theoretical counts (**TNC**) can be calculated as shown:

Where **TB** = Base Temperature (Typically 60° F)

TA = Actual Gas Temperature

Therefore:

Theoretical Number of Counts (**TNC**) =

$$\text{For Fahrenheit} \quad \frac{(460 + \mathbf{TB}) \times (\text{Number of Cycles} \times 100)}{460 + \mathbf{TA}}$$

Example: For a 25 cycle test, the Theoretical Number of Counts (**TNC**) for gas temperature of 70.0°F and a 60° F base temperature is calculated as follows:

$$\begin{aligned} &= \frac{(460 + 60) \times (25 \times 100)}{460 + 70.0} \\ &= \frac{1,300,000}{530.0} = 2452.8 \end{aligned}$$

C. Combined Accuracy Test (TC)

To run a combined accuracy test, follow the “Equipment Set-up” and the “To Configure And Run A Meter Test” procedures.

NOTE:

It is extremely important that the temperature environment in which the test will be conducted is stable. Temperature fluctuations of 1°F can easily result in a ±0.2 percent error in the test results. The section entitled “Measurement Uncertainty of the ROOTS, Model 5 Transfer Prover” contains information regarding the uncertainty of a combined accuracy (TC) test.

For manually start/stopped tests, a large enough test volume should be selected to compensate for any error introduced by the operator. Typically, a configuration where +/- 1.0 cubic foot per 1000 cubic feet of test volume equates to an error of less than +/-0.1%.

Confirm the BASE TEMPERATURE of the temperature compensated meter is entered correctly for the BASE TEMPERATURE CORRECTION field. The BASE TEMPERATURE is usually 60°F or 15°C for most meters, but other base temperatures can be used.

Testing Continuously Compensated meters:

Make the following configuration settings in the test configuration screen:

Click TEST CONTROL MODE, and select the appropriate selection; ID, OPTO, or MANUAL. When selecting the METER OUTPUT, select TC and highlight the "DIAPHRAGM TC" inside the "TC Options." For Diaphragm meters select a test volume large enough to ensure full rotations of the Instrument drive, tangents and linkages per the meter manufacturer's minimum requirements. This will help assure more accurate and repeatable results.

Testing Intermittently Compensated ROOTS Meters:

Dresser recommends using either the RS-PB or RS-LCD optical pickup to test ROOTS MECHANICAL TC meters. The ID PULSER unit should not be used to test Intermittently Compensated ROOTS Meters, as results can vary widely.

Make the following configuration settings in the test configuration screen:

Click TEST CONTROL MODE, and select "OPTO." When selecting the METER OUTPUT, select TC and highlight the "ROOTS MECHANICAL TC" or "ROOTS MECHANICAL TC 16M ONLY" inside the "TC Options."

Connect the ROOTS TC meter as for testing standard or non-TC meters. Testing with the RS type optical scanner, Dresser recommends the following minimum test volume values to equate to 400 PULSES/TEST, for each appropriate meter size corresponding to the appropriate TC option:

METER CAPACITY	TC OPTION SELECTION	PULSES/TEST (PPT)	TEST VOLUME
8C-11M	ROOTS MECHANICAL TC	400	200 CF
16M	16M ONLY ROOTS MECHANICAL TC	400	2000 CF
(8C – 3M) (G16 – G65)	ROOTS MECHANICAL TC: 8C – 3M	400	2 m ³
(5M – 16M) (G160-G250)	ROOTS MECHANICAL TC: 5M – 16M	400	20 m ³

The drive rate of the TC unit refers to the volume of gas measured for each complete cycle of the least significant digit of the compensated odometer (the furthest right wheel). TC odometers have 10 segments; each segment is equal to 1/10th of the drive rate. If the TC's drive rate = 10 CF, the total number of segments seen by the scanner during a 200 CF test would be 200. When "ROOTS MECHANICAL TC" or "ROOTS MECHANICAL TC 16M ONLY" is selected it causes the Prover Software to count transitions from black to white and back rather than complete pulses or blocks. Two transitions make up each pulse. This is why you must double the number of pulses for all ROOTS MECHANICAL TC options listed above. If you would normally enter 200 PPT for an uncorrected meter, for a temperature compensated meter test you would enter two times 200, or 400 PPT.

**Table 1 - Temperature Cycle Testing -Theoretical Number of Counts (TNC)
for specified temperature in degrees Fahrenheit (°F) and degrees Celsius (°C).
Based on 25 Temperature Compensation Cycles.**

°F	TNC	°F	TNC	°F	TNC	°F	TNC	°F	TNC	°F	TNC
50.0	2549.0	55.0	2524.3	60.0	2500.0	65.0	2476.2	70.0	2452.8	75.0	2429.9
50.1	2548.5	55.1	2523.8	60.1	2499.5	65.1	2475.7	70.1	2452.4	75.1	2429.5
50.2	2548.0	55.2	2523.3	60.2	2499.0	65.2	2475.2	70.2	2451.9	75.2	2429.0
50.3	2747.5	55.3	2722.8	60.3	2498.6	65.3	2474.8	70.3	2451.4	75.3	2428.5
50.4	2547.0	55.4	2522.3	60.4	2498.1	65.4	2474.3	70.4	2451.0	75.4	2428.1
50.5	2546.5	55.5	2521.8	60.5	2497.6	65.5	2473.8	70.5	2450.5	75.5	2427.6
50.6	2546.0	55.6	2521.3	60.6	2497.1	65.6	2473.4	70.6	2450.1	75.6	2427.2
50.7	2545.5	55.7	2520.8	60.7	2496.6	65.7	2472.9	70.7	2449.6	75.7	2426.7
50.8	2545.0	55.8	2520.4	60.8	2496.2	65.8	2472.4	70.8	2449.1	75.8	2426.3
50.9	2544.5	55.9	2519.9	60.9	2495.7	65.9	2472.0	70.9	2448.7	75.9	2425.8
51.0	2544.0	56.0	2519.4	61.0	2495.2	66.0	2471.5	71.0	2448.2	76.0	2425.4
51.1	2543.5	56.1	2518.9	61.1	2494.7	66.1	2471.0	71.1	2447.7	76.1	2424.9
51.2	2543.0	56.2	2518.4	61.2	2494.2	66.2	2470.5	71.2	2447.3	76.2	2424.5
51.3	2542.5	56.3	2517.9	61.3	2493.8	66.3	2470.1	71.3	2446.8	76.3	2424.0
51.4	2542.0	56.4	2517.4	61.4	2493.3	66.4	2469.6	71.4	2446.4	76.4	2423.6
51.5	2541.5	56.5	2516.9	61.5	2492.8	66.5	2469.1	71.5	2445.9	76.5	2423.1
51.6	2541.0	56.6	2516.5	61.6	2492.3	66.6	2468.7	71.6	2445.4	76.6	2422.7
51.7	2540.6	56.7	2516.0	61.7	2491.9	66.7	2468.2	71.7	2445.0	76.7	2422.2
51.8	2540.1	56.8	2515.5	61.8	2491.4	66.8	2467.7	71.8	2444.5	76.8	2421.8
51.9	2539.6	56.9	2515.0	61.9	2490.9	66.9	2467.3	71.9	2444.1	76.9	2421.3
52.0	2539.1	57.0	2514.5	62.0	2490.4	67.0	2466.8	72.0	2443.6	77.0	2420.9
52.1	2538.6	57.1	2514.0	62.1	2489.9	67.1	2466.3	72.1	2443.1	77.1	2420.4
52.2	2538.1	57.2	2513.5	62.2	2489.5	67.2	2465.9	72.2	2442.7	77.2	2420.0
52.3	2537.6	57.3	2513.0	62.3	2489.0	67.3	2465.4	72.3	2442.2	77.3	2419.5
52.4	2537.1	57.4	2512.6	62.4	2488.5	67.4	2464.9	72.4	2441.8	77.4	2419.1
52.5	2536.6	57.5	2512.1	62.5	2488.0	67.5	2464.5	72.5	2441.3	77.5	2418.6
52.6	2536.1	57.6	2511.6	62.6	2487.6	67.6	2464.0	72.6	2440.9	77.6	2418.2
52.7	2535.6	57.7	2511.1	62.7	2487.1	67.7	2463.5	72.7	2440.4	77.7	2417.7
52.8	2535.1	57.8	2510.6	62.8	2486.6	67.8	2463.1	72.8	2439.9	77.8	2417.3
52.9	2534.6	57.9	2510.1	62.9	2486.1	67.9	2462.6	72.9	2439.5	77.9	2416.8
53.0	2534.1	58.0	2509.7	63.0	2485.7	68.0	2462.1	73.0	2439.0	78.0	2416.4
53.1	2533.6	58.1	2509.2	63.1	2485.2	68.1	2461.7	73.1	2438.6	78.1	2415.9
53.2	2533.1	58.2	2508.7	63.2	2484.7	68.2	2461.2	73.2	2438.1	78.2	2415.5
53.3	2532.6	58.3	2508.2	63.3	2484.2	68.3	2460.7	73.3	2437.7	78.3	2415.0
53.4	2532.1	58.4	2507.7	63.4	2483.8	68.4	2460.3	73.4	2437.2	78.4	2414.6
53.5	2531.6	58.5	2507.2	63.5	2483.3	68.5	2459.8	73.5	2436.7	78.5	2414.1
53.6	2531.2	58.6	2506.7	63.6	2482.8	68.6	2459.3	73.6	2436.3	78.6	2413.7
53.7	2530.7	58.7	2506.3	63.7	2482.3	68.7	2458.9	73.7	2435.8	78.7	2413.2
53.8	2530.2	58.8	2505.8	63.8	2481.9	68.8	2458.4	73.8	2435.4	78.8	2412.8
53.9	2529.7	58.9	2505.3	63.9	2481.4	68.9	2457.9	73.9	2434.9	78.9	2412.3
54.0	2529.2	59.0	2504.8	64.0	2480.9	69.0	2457.5	74.0	2434.5	79.0	2411.9
54.1	2528.7	59.1	2504.3	64.1	2480.4	69.1	2457.0	74.1	2434.0	79.1	2411.4
54.2	2528.2	59.2	2503.9	64.2	2480.0	69.2	2456.5	74.2	2433.5	79.2	2411.0
54.3	2527.7	59.3	2503.4	64.3	2479.5	69.3	2456.1	74.3	2433.1	79.3	2410.5
54.4	2527.2	59.4	2502.9	64.4	2479.0	69.4	2455.6	74.4	2432.6	79.4	2410.1
54.5	2526.7	59.5	2502.4	64.5	2478.6	69.5	2455.1	74.5	2432.2	79.5	2409.6
54.6	2526.2	59.6	2501.9	64.6	2478.1	69.6	2454.7	74.6	2431.7	79.6	2409.2
54.7	2525.7	59.7	2501.4	64.7	2477.6	69.7	2454.2	74.7	2431.3	79.7	2408.7
54.8	2525.3	59.8	2501.0	64.8	2477.1	69.8	2453.8	74.8	2430.8	79.8	2408.3
54.9	2524.8	59.9	2500.5	64.9	2476.7	69.9	2453.3	74.9	2430.4	79.9	2407.9

Spare Part List		
Description	Part Number	Quantity Req'd.
012849-000	Tool Box/Large Black Accessory Case	1
052579-000	Field Meter Pressure Adapter	1
052580-000	Field Meter Pressure & Temperature Adapter	1
051998-000	Field Meter Temperature Probe	1
052191-000	Field Meter Instrument Drive Pulsar	1
051993-000	Field Meter Instrument Drive Pulsar Cable	1
052485-000	Manual Start/Stop Cable	1
011290-001	Blue Pressure Tubing	(2) 48"
011290-002	Black Pressure Tubing	(2) 4'
052987-102	Software Diskettes (v3.0 for DOS)	1
056664-000	Software (v 5.x for Window)	1
012850-000	25' Electrical Extension Cord	1
052017-000	Computer Cable to Controller	1
052000-000	Field Meter Junction Box	1
011323-008	3" Aluminum Hose Plug	1
051992-000	Cable Master Meter to Controller	(1) 45"
051992-100	Cable Master Meter to Controller (Extended Length)	(1) 25'
012444-000	3" Kamlock Cap	1
011501-002	Thumb Screw	2
042991-000	Clamp for holding ID pulsar	2
052188-000	Blower - 10M Provers	2
052188-001	Blower - Mobile 5	2
052188-002	Blower - Small Blowers on 20M and 80M Provers	2
046894-000	Blower Brushes	4
043441-000	25' Prover Hose for 10M/2M and 10M Part of 80M	1
053181-000	Mobile 5 - 12' Hose	1
057519-000	25' Prover Hose for 20M Prover	1
	Consult Factory for 80M Hose(s)	
013287-000	Hose Gasket	2
052287-002	10M Master Meter Pressure Adapter Kit	1
051999-002	10M Master Meter Temperature Probe	1
012983-000	10M Master Meter Quick Disconnect Nipple Outlet	1
054992-100	10M Master Meter Quick Disconnect Nipple Screened Inlet	1
052288-003	2M Master Meter Conversion Kit	1
052287-001	2M Master Meter Pressure Adapter Kit	2
051999-001	2M Master Meter Temperature Probe	1
012852-005	2M Master Meter Quick Disconnect Nipple Outlet	1
054992-000	2M Master Meter Quick Disconnect Nipple Screened Inlet	1
012851-002	2" Test Plug - 10M Provers only	1
012844-002	Quick Disconnect Shut Off Coupler for Pressure Fittings	4
012796-003	Knurls (Flareless Fitting)	4
012418-002	Vibration Damper for Controller & for the Computer Table	5
052013-001	Controller (10M)	1
052917-000	Controller (80M)	1
052528-000	Controller (20M)	1
053127-000	Controller (5M)	1
013355-000	Resetable Circuit Breaker	1
052005-000	Triac Board (10M only) –	
	110 = Expansion Triac Board (20M & 80M)	1
	120 = Expandable Triac Board (20M & 80M)	
012840-003	Solenoid (10M only)	1
012505-003	Pulsation Dampener (Snubber)	4
012918-001	Seal Fitting for Temperature Probes	3
011900-000	Cart Tire and Wheel (10M only)	2
052899-000	Acoustic Filter	1
052519-100	RS-LCD Scanner Kit	1
052519-200	RS-PB Scanner Kit	1
012966-000	Inverter (10M only)	1
011321-001	Male Quick Disconnect Nipple for Hose Adapter	1
011322-001	Female Quick Disconnect Nipple for Hose Adapter	1

2 Year Warranty

Dresser Roots Meters & Instruments (herein referred to as the Company) agrees to supply equipment of good design and first class material and workmanship. In the event of any defect of material or workmanship, the Company will repair F.O.B. place of manufacture, or furnish without charge, place of manufacture, similar part or parts which, within one year after their shipment, are proven to have been so defective at the time of shipment, provided the Purchaser gives the Company immediate written notice of such alleged defects.

Notwithstanding the proceeding, warranty claims involving Model 5 ROOTS Prover(s) used only to prove meter volume accuracy, may be made within two (2) years from shipment. A complete list of products covered by this extended warranty is available by writing our general offices.

Except as herein provided, there are no other warranties, either expressed or implied (including without limitation the implied warranties of merchantability and fitness for particular purpose), and any such warranties are hereby expressly disclaimed. The Company, except in the case of gross or willful negligence, shall not be liable for any damages for cause or reason whatsoever, either direct, indirect, special or consequential, arising out of any contract or from the operation or failure properly to operate any apparatus or equipment sold. No allowance will be made for repairs or alterations unless made with the written consent first obtained from the Company. Neither shall the Company be held liable or in any way responsible for work done, apparatus furnished, or repairs made by others. Auxiliary equipment supplied hereunder not manufactured by the Company and so identified by the Company is subject to the warranty of the manufacturer thereof and the Purchaser's recourse shall be limited to such other warranty.

For additional information, consult your Yellow Pages under Meters - Dresser ROOTS Gas Meters, or contact our general offices at:

Dresser Roots Meters & Instruments

Dresser, Inc.
P. O. Box 42176
Houston, Texas 77242-2176
Phone: 832-590-2303
Fax: 832-590-2494

Dresser UK, Ltd.

Dresser House
Gillibrands Road
East Gillibrands Estate
Skelmersdale, Lancashire WN8 9TU
Phone: 44-(0)-1695-52600
Fax: 44-(0)-1695-52610

Dresser Industrial Products, B.V.

Industrieterrein 4
NL-5981 NK Panningen
The Netherlands
Phone: +31 (0)-77-306-6040
Fax: +31 (0)-77-307-6494

**Roots Meters & Instruments
Dresser, Inc.**

16240 Port Northwest Drive
Houston, Texas 77041-2645 USA
Inside US Ph: 800.521.1114 Fax: 800.335.5224
Outside US Ph: 832.590.2303 Fax: 832.590.2494

©2004,2008 Dresser, Inc.
ROOTS, and DRESSER are registered trademarks of Dresser, Inc.
Windows is a registered trademark of Microsoft Corporation.
LabVIEW is a trademark of National Instruments Corporation.



www.dresser.com

RPO_5
10.08