



ROOTS® Meters & Instruments

DATA SHEET

SERIES B3: 7MI75 ROOTS® Meter

	UNITS	Imperial	UNITS	Metric
Temperature Range	deg. F	-40 to +140	deg. C	-40 to +60
Base Rating (Q Max.)	acfh	7000	m ³ /h	200,0
Max. Operating Pressure (MAOP)	psig	175	kPa	1200
Leak Test (125% MAOP)	psig	219	kPa	1510
Static Test (2 x MAOP)	psig	350	kPa	2400
Rangeability +/- 1%	ratio	67:1	ratio	67:1
Rangeability +/- 2%	ratio	115:1	ratio	115:1
Start Rate	cfh	5.33	m ³ /h	0,1509
Stop Rate	cfh	3.39	m ³ /h	0,0960
Flow Rate @ 0.5" w.c., Gas	cfh	5400	m ³ /h	152,9
Avg. Differential, 100% Flow	in. w.c.	1.6	mbar	4,0
Max. Pressurization Rate	psig/sec	5	kPa/sec	35
Max. Operating Speed	rpm	1867	rpm	1867
Gear Ratio	ratio	160:1	ratio	564,9038:1
Displaced Volume/Revolution	cf	0.0625	m ³	0,001770
Drive Rate, CD	cf/rev	10	m ³ /rev	1
Drive Rate, TD	cf/rev	100	m ³ /rev	10
Temp. Compensating Range (TC,TD)	deg. F	-20 to +120	deg. C	-29 to +49
Min. Odometer Reading	cf	0.2	m ³	0,02
Odometer Turnover	yrs.	1.63	yrs.	5,77
Nominal Pipe Size	in.	3	mm	80
Flange-to-Flange	in.	9-1/2	mm	241,3
Flange Connection	ANSI	150#FF	ANSI	150#FF
Bolts per Flange	qty.	4	qty.	4
Bolt Size ¹	in.	5/8 - 11	in.	5/8 - 11
Flange Bolt Hole Depth	in.	15/16	mm	23,8
Bolt Torque: Lubricated/Non-Lub.	ft.-lb.	55/60	N-m	74/81
Restricting Orifice (120%)	in.	13/16	mm	20,638
Oil Capacity – Side Inlet	oz.	3	ml	89
Oil Capacity – Top Inlet	oz.	21.9	ml	648
Counter Version (CTR) ²				
Net Weight	lbs.	52	kg	23,6
Shipping Weight	lbs.	58	kg	26,3
Carton Size	in.	34x 13 x 12	cm	86 x 33 x 31
Counter with Instrument Drive (CD) ²				
Net Weight	lbs.	58	kg	26,3
Shipping Weight	lbs.	64	kg	29,0
Carton Size	in.	38 x 15 x 16	cm	97 x 38 x 41

NOTES:

¹ Bolt Length varies by application.

² Weights and dimensions available for CPS,TC,TD,TPS upon request.

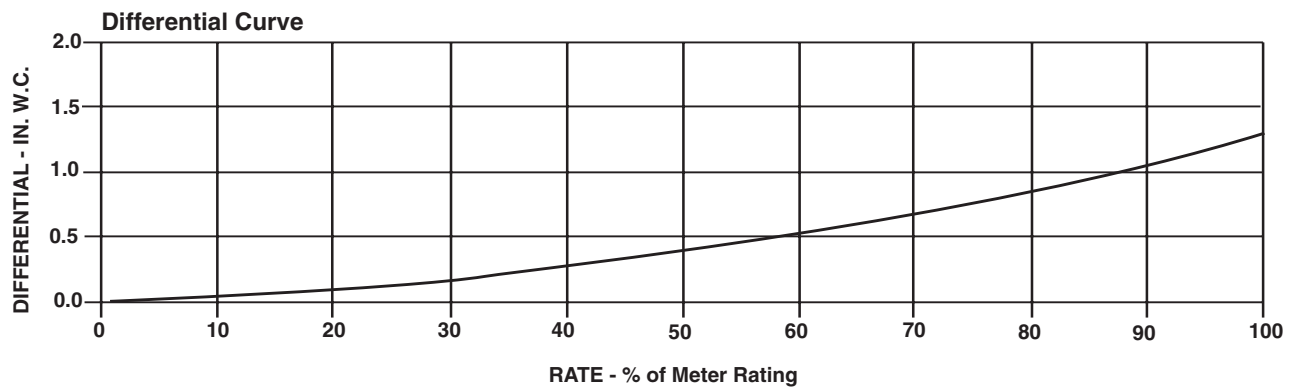
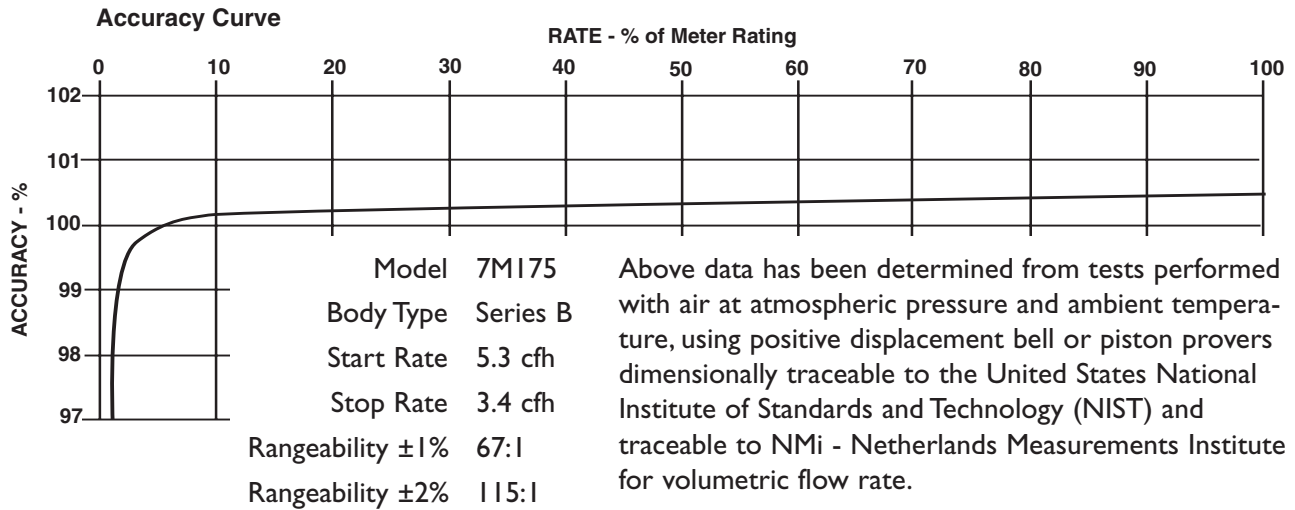

7M175 Series B3	Overall Length		Overall Height		Width (Flange/Flange)		Centerline to Accessory End (CL-AU)		Request Detailed Drawing Number
	inches	mm	inches	mm	inches	mm	inches	mm	
CTR / TC	17-13/16	452	8-7/8	225	9-1/2	241	11-5/16	273	D054518-000
CD / TD	21-19/32	548	8-7/8	225	9-1/2	241	15-3/32	383	D054432-000
GPS / TPS	19-15/16	506	8-7/8	225	9-1/2	241	13-7/16	341	D054671-000
IMC/C	23-3/16	589	8-7/8	225	9-1/2	241	14-15/16	379	D056487-000
IMC/W	24-3/16	614	8-7/8	225	9-1/2	241	17-11/16	449	D056703-000

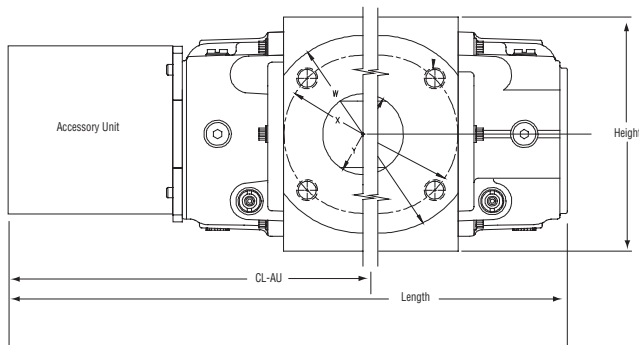

To order

Specify: Meter Series, Size and Type (i.e., ROOTS Meter Series B3 7M175 CD).

For CD or TD, specify Inlet (Top or Side) and ID Rotation (CW-B or CCW-A).

For Pulsar, specify Single or Dual Connectors and Connector Type (MS Circular, Conduit or Cable Gland).

For more specific ordering information on the electronic products, request: TS:SSP, TS:IMC/C or S:IMC/W.

Contact the factory for other available information, options, or special requests.



Dresser Roots Meters & Instruments

P. O. Box 42176
 Houston, TX USA 77242-2716
 website: www.dresser.com

Dresser, Inc.

Inside US Ph: 800.521.1114 Fax: 800.335.5224
 Outside US Ph: 832.590.2303 Fax: 832.590.2494
 www.rootsmeters.com