



# ROOTS<sup>®</sup> Meters & Instruments

## DATA SHEET

### SERIES B3: 5MI75 ROOTS<sup>®</sup> Meter

	UNITS Imperial	UNITS Metric
Temperature Range	deg. F -40 to +140	deg. C -40 to +60
Base Rating (Q Max.)	acfh 5000	m <sup>3</sup> /h 141,5
Max. Operating Pressure (MAOP)	psig 175	kPa 1200
Leak Test (125% MAOP)	psig 219	kPa 1510
Static Test (2 x MAOP)	psig 350	kPa 2400
Rangeability +/- 1%	ratio 120:1	ratio 120:1
Rangeability +/- 2%	ratio 215:1	ratio 215:1
Start Rate	cfh 1.2	m <sup>3</sup> /h 0,0340
Stop Rate	cfh 0.8	m <sup>3</sup> /h 0,0227
Flow Rate @ 0.5" w.c., Gas	cfh 3975	m <sup>3</sup> /h 112,6
Avg. Differential, 100% Flow	in. w.c. 1.1	mbar 2,6
Max. Pressurization Rate	psig/sec 5	kPa/sec 35
Max. Operating Speed	rpm 2250	rpm 2250
Gear Ratio	ratio 270:1	ratio 953,125:1
Displaced Volume/Revolution	cf 0.037037	m <sup>3</sup> 0,0001049
Drive Rate, CD	cf/rev 10	m <sup>3</sup> /rev 1
Drive Rate, TD	cf/rev 100	m <sup>3</sup> /rev 10
Temp. Compensating Range (TC,TD)	deg. F -20 to +120	deg. C -29 to +49
Min. Odometer Reading	cf 0.2	m <sup>3</sup> 0.002
Odometer Turnover	yrs. 2.28	yrs. 8,06
Nominal Pipe Size	in. 3	mm 80
Flange-to-Flange	in. 6-3/4	mm 172
Flange Connection	ANSI 150#FF	ANSI 150#FF
Bolts per Flange	qty. 4	qty. 4
Bolt Size <sup>1</sup>	in. 5/8 - 11	in. 5/8 - 11
Flange Bolt Hole Depth	in. 15/16	mm 23,8
Bolt Torque: Lubricated/Non-Lub.	ft.-lb. 55/60	N-m 74/81
Restricting Orifice (120%)	in. 23/32	mm 18,256
Oil Capacity – Side Inlet	oz. 1.25	ml 37
Oil Capacity – Top Inlet	oz. 7.65	ml 226
<i>Counter Version (CTR)<sup>2</sup></i>		
Net Weight	lbs. 35	kg 15,9
Shipping Weight	lbs. 38	kg 17,2
Carton Size	in. 27 x 11 x 9	cm 69 x 28 x 23
<i>Counter with Instrument Drive (CD)<sup>2</sup></i>		
Net Weight	lbs. 38	kg 17,2
Shipping Weight	lbs. 41	kg 18,6
Carton Size	in. 31 x 15 x 13	cm 79 x 38 x 33

NOTES:

<sup>1</sup> Bolt Length varies by application.

<sup>2</sup> Weights and dimensions available for CPS, TC, TD, TPS upon request.

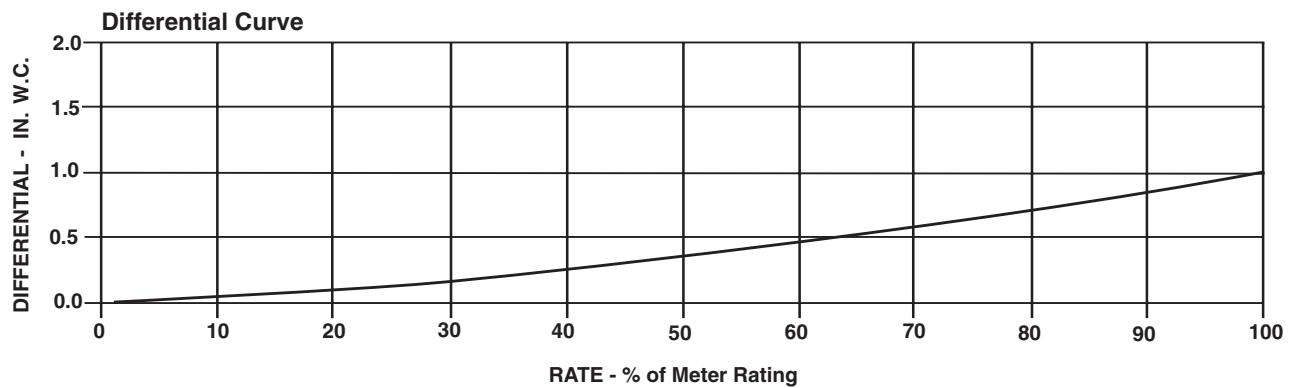
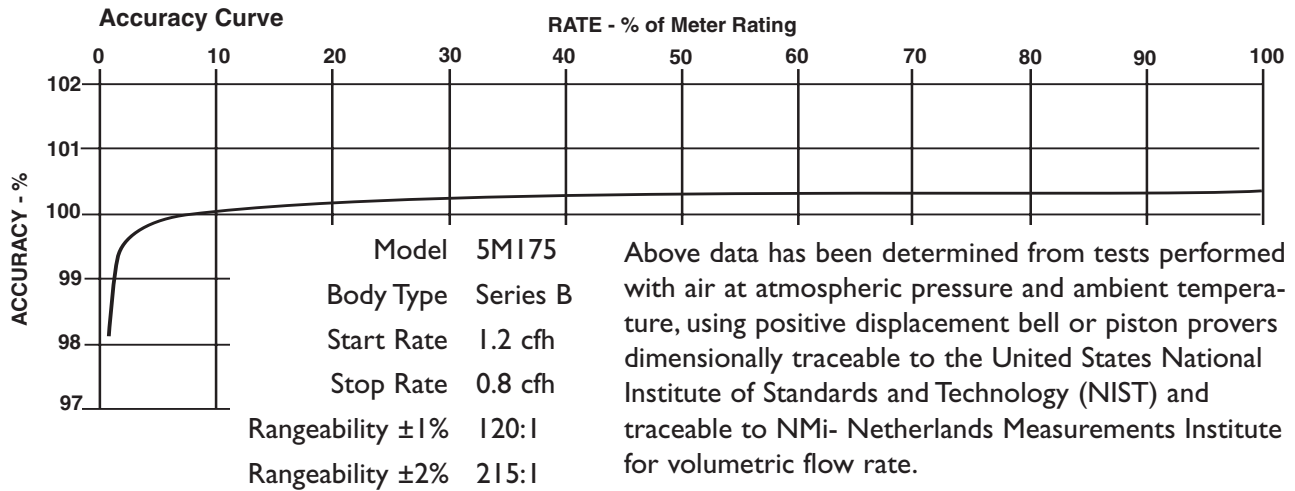

5M175 Series B3	Overall Length		Overall Height		Width (Flange/Flange)		Centerline to Accessory End (CL-AU)		Request Detailed Drawing Number
	inches	mm	inches	mm	inches	mm	inches	mm	
CTR / TC	20	508	6-31/32	177	6-3/4	172	12-5/16	313	D054517-000
CD / TD	23-27/32	606	6-31/32	177	6-3/4	172	16-5/32	411	D054431-000
CPS / TPS	22-1/8	562	6-31/32	177	6-3/4	172	14-7/16	368	D054670-000
IMC/C	23-1/2	597	6-31/32	177	6-3/4	172	15-13/16	402	D056486-000
IMC/W	24-1/2	622	6-31/32	177	6-3/4	172	16-13/16	427	D056702-000

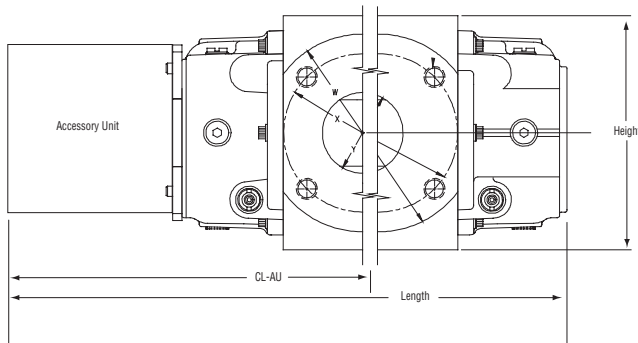

**To order**

Specify: Meter Series, Size and Type (i.e., ROOTS Meter Series B3 5M175 CD).  
 For CD or TD, specify Inlet (Top or Side) and ID Rotation (CW-B or CCW-A).  
 For Pulsar, specify Single or Dual Connectors and Connector Type (MS Circular, Conduit or Cable Gland).  
 For more specific ordering information on the electronic products, request: TS:SSP, TS:IMC/C or S:IMC/W.  
 Contact the factory for other available information, options, or special requests.



**Dresser Roots Meters & Instruments**

P. O. Box 42176  
 Houston, TX USA 77242-2716  
 website: www.dresser.com

**Dresser, Inc.**

Inside US Ph: 800.521.1114 Fax: 800.335.5224  
 Outside US Ph: 832.590.2303 Fax: 832.590.2494  
 www.rootsmeters.com