



ROOTS® Meters & Instruments

DATA SHEET

SERIES B3: 2MI75 ROOTS® Meter

	UNITS Imperial	UNITS Metric
Temperature Range	deg. F -40 to +140	deg. C -40 to +60
Base Rating (Q Max.)	acfh 2000	m ³ /h 56,6
Max. Operating Pressure (MAOP)	psig 175	kPa 1200
Leak Test (125% MAOP)	psig 219	kPa 1510
Static Test (2 x MAOP)	psig 350	kPa 2400
Rangeability +/- 1%	ratio 68:1	ratio 68:1
Rangeability +/- 2%	ratio 126:1	ratio 126:1
Start Rate	cfh 1.9	m ³ /h 0,0538
Stop Rate	cfh 1.1	m ³ /h 0,0311
Flow Rate @ 0.5" w.c., Gas	cfh 2000	m ³ /h 56,6
Avg. Differential, 100% Flow	in. w.c. 0.65	mbar 1,6
Max. Pressurization Rate	psig/sec 5	kPa/sec 35
Max. Operating Speed	rpm 1667	rpm 1667
Gear Ratio	ratio 500:1	ratio 176,4705:1
Displaced Volume/Revolution	cf 0.02	m ³ 0,000566
Drive Rate, CD	cf/rev 10	m ³ /rev 0,1
Drive Rate, TD	cf/rev 100	m ³ /rev 1
Temp. Compensating Range (TC,TD)	deg. F -20 to +120	deg. C -29 to +49
Min. Odometer Reading	cf 0.2	m ³ 0,002
Odometer Turnover	yrs. 5.7	yrs. 2,02
Nominal Pipe Size	in. 2	mm 50,8
Flange-to-Flange	in. 6-3/4	mm 172
Flange Connection	ANSI 150#FF	ANSI 150#FF
Bolts per Flange	qty. 4	qty. 4
Bolt Size ¹	in. 5/8 - 11	in. 5/8 - 11
Flange Bolt Hole Depth	in. 15/16	mm 23,8
Bolt Torque: Lubricated/Non-Lub.	ft.-lb. 55/60	N-m 74/81
Restricting Orifice (120%)	in. 7/16	mm 11,113
Oil Capacity – Side Inlet	oz. 1.25	ml 37
Oil Capacity – Top Inlet	oz. 7.65	ml 226
<i>Counter Version (CTR)²</i>		
Net Weight	lbs. 26	kg 11,8
Shipping Weight	lbs. 28	kg 12,7
Carton Size	in. 27 x 11 x 9	cm 69 x 28 x 23
<i>Counter with Instrument Drive (CD)²</i>		
Net Weight	lbs. 30	kg 13,6
Shipping Weight	lbs. 32	kg 14,5
Carton Size	in. 31 x 15 x 13	cm 79 x 38 x 33

NOTES:

¹ Bolt Length varies by application.

² Weights and dimensions available for CPS, TC, TD, TPS upon request.

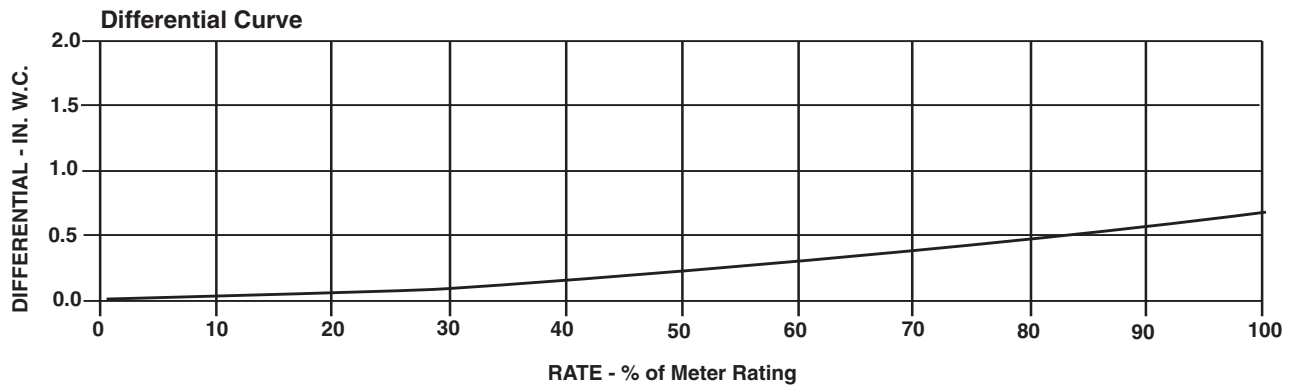
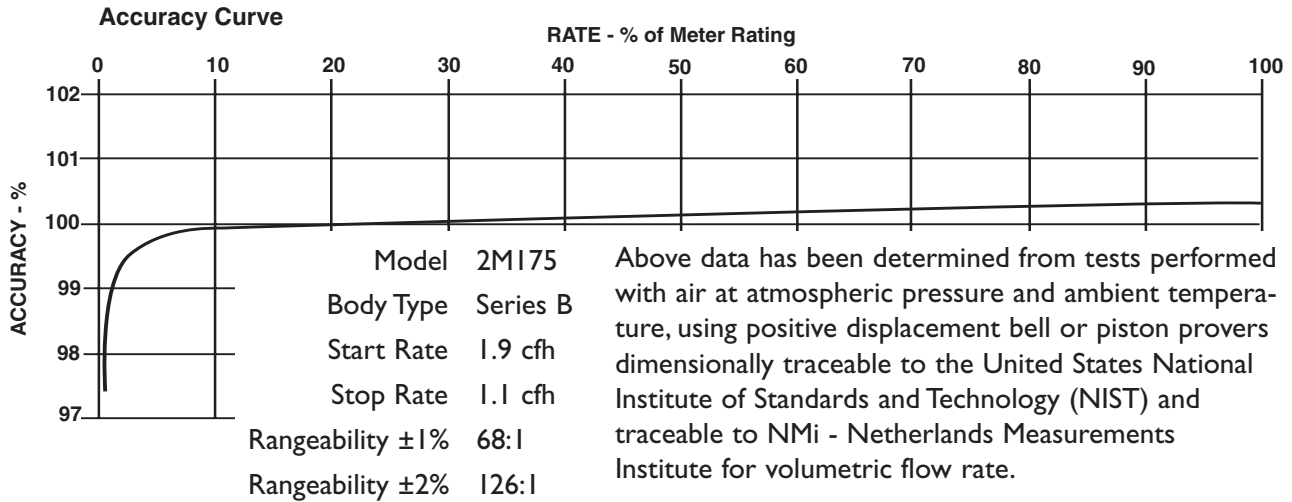

2M175 Series B3	Overall Length		Overall Height		Width (Flange/Flange)		Centerline to Accessory End (CL-AU)		Request Detailed Drawing Number
	inches	mm	inches	mm	inches	mm	inches	mm	
CTR / TC	15-29/32	404	6-31/32	177	6-3/4	172	10-1/4	260	D054517-000
CD / TD	19-25/32	503	6-31/32	177	6-3/4	172	14-1/8	359	D054431-000
CPS / TPS	18-1/32	458	6-31/32	177	6-3/4	172	12-3/8	314	D054670-000
IMC/C	19-13/32	493	6-31/32	177	6-3/4	172	13-3/4	349	D056486-000
IMC/W	20-13/32	518	6-31/32	177	6-3/4	172	14-3/4	375	D056702-000

To order

Specify: Meter Series, Size and Type (i.e., ROOTS Meter Series B3 2M175 CD).

For CD or TD, specify Inlet (Top or Side) and ID Rotation (CW-B or CCW-A).

For Pulsar, specify Single or Dual Connectors and Connector Type (MS Circular, Conduit or Cable Gland).

For more specific ordering information on the electronic products, request: TS:SSP, TS:IMC/C or S:IMC/W.

Contact the factory for other available information, options, or special requests.

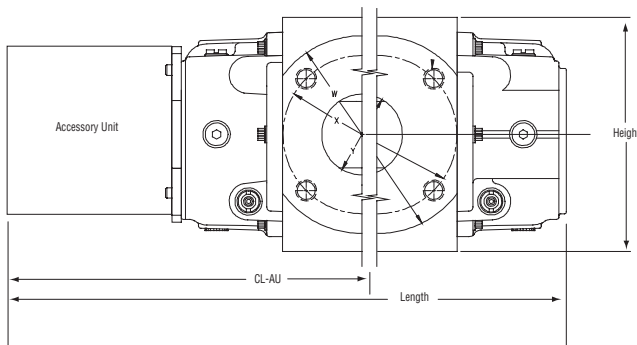

Dresser Roots Meters & Instruments

P. O. Box 42176
Houston, TX USA 77242-2716
website: www.dresser.com

Dresser, Inc.

Inside US Ph: 800.521.1114 Fax: 800.335.5224
Outside US Ph: 832.590.2303 Fax: 832.590.2494
www.rootsmeters.com